

### STR700 SmartLine Remote Diaphragm Seals Specification 34-ST-03-104, February 2025



#### Introduction

Part of the SmartLine® family of products, the STR700 is a series of pressure transmitters hydraulically matched and optimized with a complete set of remote diaphragm seals. Utilizing the same high performance sensor technology of the ST 800 product line Honeywell has optimized the mechanical and hydraulic designs in order to minimize the typical effects of temperature on remote seal systems. The SmartLine family is also fully tested and compliant with Experion® PKS providing the highest level of compatibility assurance and integration capabilities. SmartLine easily meets the most demanding application needs for pressure measurement applications.

#### Best in Class Transmitter Features:

- Accuracies up to 0.075% of span.
- Automatic static pressure & temperature compensation.
- Rangeability up to 100:1.
- Multiple local display capabilities.
- External zero, span, & configuration capability.
- Polarity insensitive electrical connections.
- Comprehensive on-board diagnostic capabilities.
- Integral Dual Seal design for highest safety based on ANSI/NFPA 70-202 and ANSI/ISA 12.27.0.
- World class overpressure protection.
- Full compliance to SIL 2/3 requirements.
- Modular design characteristics.
- Available with additional 4-year warranty.

#### Span & Range Limits:

Model	URL psid (bar)	LRL psid (bar)	Min Span psid (bar)
STR73D	100 (7.0)	-100 (-7.0)	0.9 (0.062)
STR74G	500 (35.0)	-14.7 (-1.0)	5 (0.35)



Figure 1 – STR700 Remote Diaphragm Seal Unit

#### Typical Diaphragm Seal applications

- High Process Temperatures.
- Viscous or Suspended Solids.
- Highly Corrosive Process Materials.
- Sanitary Applications.
- Applications with Hydrogen Permeation Possibilities.
- Level Applications with Maintenance Intensive Wet Legs.
- Applications requiring remote Transmitter Mounting.
- Tank Applications with Density or Interface Measurements.

#### Communications/Output Options:

- Honeywell Digitally Enhanced (DE)
- HART ® (version 7.0)

All transmitters are available with the above listed communications protocols.

## Description

The SmartLine family pressure transmitters are designed around a high performance piezo-resistive sensor. This one sensor integrates multiple sensors linking process pressure measurement with on-board static pressure (DP Models) and temperature compensation measurements. This level of performance allows the ST 700 to replace most competitive transmitters available today.

## Unique Indication/Display Option

The ST 700 modular design accommodates a standard alphanumeric LCD display or a unique advanced graphics LCD display with many unparalleled features.

### Standard LCD Display Features

- Modular (may be added or removed in the field).
- Supports HART protocol variant.
- 0, 90, 180, & 270 degree position adjustments.
- Four configurable screens.
- Standard and custom measurement units available.
- Display calculated flow (square root) value in addition to analog output signal.
- 2 Lines 6 digits PV (9.95H x 4.20W mm) 8 Characters.
- Write protect Indication.
- Built-in Basic Device Configuration through Internal or External Buttons – Range/Engineering Unit/Loop Test /Loop Calibration/Zero /Span Setting.
- Multiple language capabilities (EN, RU).

### Advanced Graphics LCD Display Features

- Modular (may be added or removed in the field).
- 0, 90, 180, & 270-degree position adjustments.
- Standard and custom measurement units available.
- Up to eight display screens with 3 formats are possible.
- Large PV with Bar Graph or PV with Trend Graph.
- Configurable screen rotation timing (1 to 30 sec).
- Display calculated flow (square root) value in addition to analog output signal.
- Unique “Health Watch” indication provides instant visibility of diagnostics.
- Multiple language capability (EN, DE, FR, IT, ES, RU, TR, CN, & JP).

## Diagnostics

SmartLine transmitters all offer digitally accessible diagnostics which aid in providing advanced warning of possible failure events minimizing unplanned shutdowns, providing lower overall operational costs.

## System Integration

- SmartLine communications protocols all meet the most current published standards for HART/DE.
- Integration with Honeywell’s Experion PKS offers the following unique advantages.
  - Tamper reporting.
  - FDM Plant Area Views with Health summaries.
  - All ST 700 units are Experion tested to provide the highest level of compatibility assurance.

## Configuration Tools

### Integral Two Button Configuration Option

Suitable for all electrical and environmental requirements, SmartLine offer the ability to configure the transmitter and display via three externally accessible buttons when either display option is selected. Zero/span capabilities are also optionally available via these buttons with or without selection of a display option.

### Handheld Configuration

SmartLine transmitters feature two-way communication and configuration capability between the operator and the transmitter. All Honeywell transmitters are designed and tested for compliance with the offered communication protocols and are designed to operate with any standards compliant handheld configuration device, such as Honeywell Versatilis Configurator.

### Personal Computer Configuration

On a personal computer or laptop, Honeywell Field Device Manager (FDM) Software and FDM Express can be used for managing HART device configurations.

## Modular Design

To help contain maintenance & inventory costs, all ST 700 transmitters are modular in design supporting the user’s ability to replace meter bodies, add indicators or change electronic modules without affecting overall performance or approval body certifications. Each meter body is uniquely characterized to provide in-tolerance performance over a wide range of application variations in temperature and pressure and due to the Honeywell advanced interface, electronic modules may be swapped with any electronics module without losing in-tolerance performance characteristics.

### Modular Features

- Meter body replacement.
- Exchange/replace electronics/comms modules\*.
- Add or remove integral indicator\*.
- Add or remove lightning protection (terminal connection)\*.

\* Field replaceable in all electrical environments (including IS) except flameproof without violating agency approvals.

With no performance effects, Honeywell’s unique modularity results in **lower inventory needs and lower overall operating costs.**

**Performance Specifications**

**Reference Accuracy** (conformance to +/-3 Sigma)

**Table 1**

Model	URL	LRL	Min Span	Maximum Turndown Ratio	Reference Accuracy <sup>1,2</sup> (% Span) Standard/Optional
STR73D	100 psi (7.0 bar)	-100 psi (-7.0bar)	0.9 psi (0.062bar)	111:1	0.075
STR74G	500 psi (35 bar)	-14.7 psi (-1.0 bar)	5 psi (0.035 bar)	100:1	0.075/0.040

Zero and span may be set anywhere within the listed (URL/LRL) range limits

**Table 2**

		Accuracy <sup>1,2</sup> (% of Span)					Combined Zero & Span Temperature Effect (% Span / 28°C (50°F))		
	Model	URL	Reference Turndown	A	B	C (see URL units)	D	E	F
Standard Accuracy	STR73D	100 psi (7.0 bar)	27.7:1	0.025	0.050	3.61 (0.25)	0.275	1.200	7.2 (0.50)
	STR74G	500 psi (35 bar)	25:1	0.005	0.060	25 (1.4)	-	-	-
High Accuracy Option	STR74G	500 psi (35 bar)	25:1	0.005	0.035	25 (1.75)			
<b>Turn Down Effect</b>							<b>Temp Effect</b>		
$\pm [A + B] \text{ if Span} \geq C$ $\pm \left[ A + B \left( \frac{C}{Span} \right) \right] \text{ if Span} < C$							$\pm \left[ D + E \left( \frac{F}{Span} \right) \right]$ $\pm \left[ A + B \left( \frac{F}{Span} \right) \right] \text{ if Span} < F$		

**Accuracy at Specified Span, Temperature and Static Pressure:** (conformance to +/-3 Sigma)

**Total Performance (% of Span):** \_\_\_\_\_

**Total Performance = +/-**  $\sqrt{(\text{Accuracy})^2 + (\text{Temp Effect})^2}$

**Total Performance Examples (for comparison):** (standard accuracy 5:1 Turndown, up to 50 °F (28°C) shift)

**STR73D @ 20 psi:** 1.477% of span

**Typical Calibration Frequency:**

Calibration verification is recommended every four (4) years.

**Notes:**

1. Terminal based Accuracy – Includes combined effects of linearity, hysteresis and repeatability. Analog output adds 0.005% of span.
2. For zero based spans and reference conditions of 25°C (77°F). 0 psi static pressure for DP, >= 0 psia for GP, 10 to 55% RH, and 316 Stainless Steel barrier diaphragm.
3. Specification applies to transmitter with 2 balanced remote seals. Apply a factor of 1.5 for temperature effect of capillary lengths greater than 10 feet.

**Operating Conditions – All Models**

Parameter	Reference Condition (at zero static)		Rated Condition		Operative Limits		Transportation and Storage	
	°C	°F	°C	°F	°C	°F	°C	°F
Ambient Temperature <sup>1</sup>	25±1	77±2	-	-	-	-	-55 to 90	-67 to 194
Humidity %RH	10 to 55		0 to 100		0 to 100		0 to 100	
Vacuum Region, Minimum Pressure mmHg absolute	Atmospheric (See Figure 4 for vacuum limitation)							
Supply Voltage, Current, and Load Resistance	HART: 10.8 to 42.4 VDC at terminals (IS versions limited to 30 VDC), 0 to 1,440 ohms DE: 15 to 49.3VDC at terminals (IS versions limited to 30VDC), 0 to 1,200 ohms (as shown in Figure 2)							
Maximum Allowable Working Pressure (MAWP) <sup>4</sup> <small>(ST 700 products are rated to Maximum Allowable Working Pressure. MAWP depends on Approval Agency and transmitter materials of construction.)</small>	MAWP is minimum of Body Rating or Seal Rating (See Model Selection Guide for Seal MAWP) Body MAWP STR73D 750 psig (51.7 bar) Bolted Process Heads STR74G 500 psig (35 bar)							

<sup>1</sup> Ambient Temperature Limit is a function of Process Interface Temperature. (See Figures 3 & 4)

LCD Display operating temperature -20°C to +70°C . Storage temperature -30°C to 80°C

<sup>4</sup> Consult factory for MAWP of ST 700 transmitters with CRN approval.

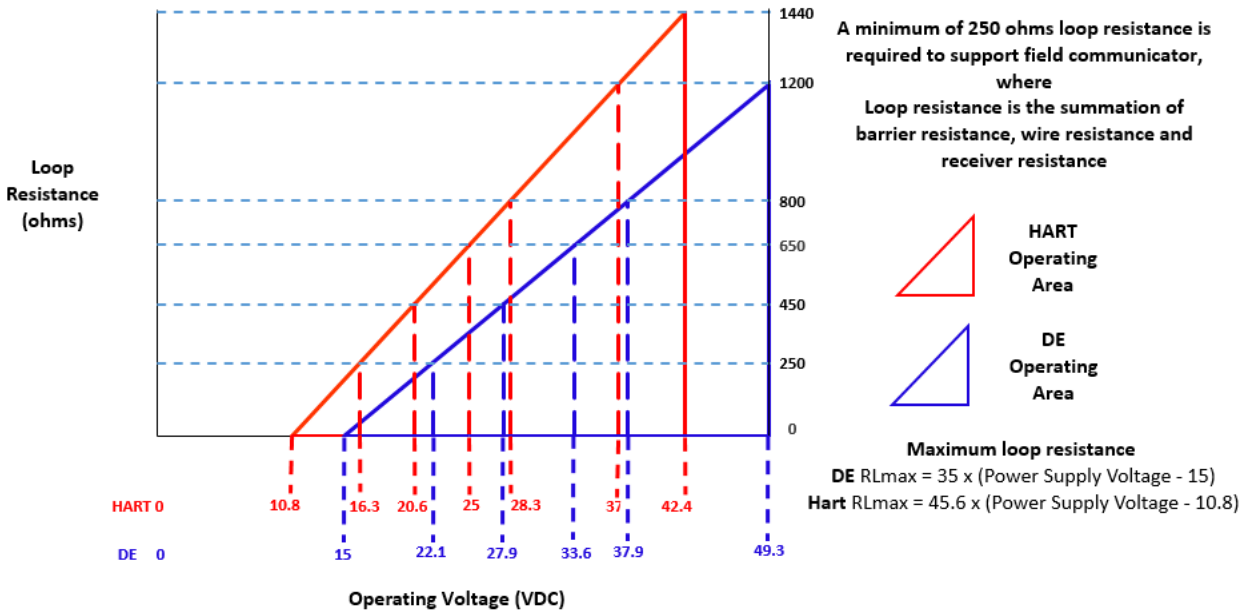

**Figure 2- Supply voltage and loop resistance**

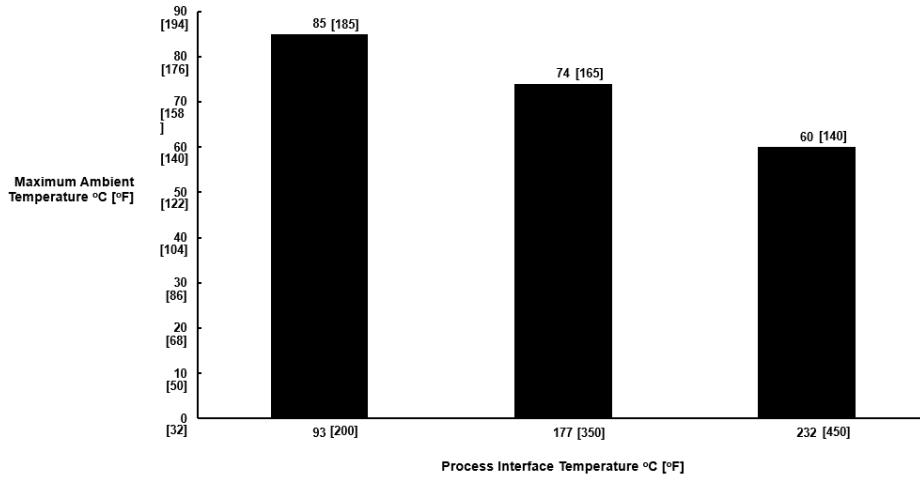

Figure 3- Ambient temperature Limits

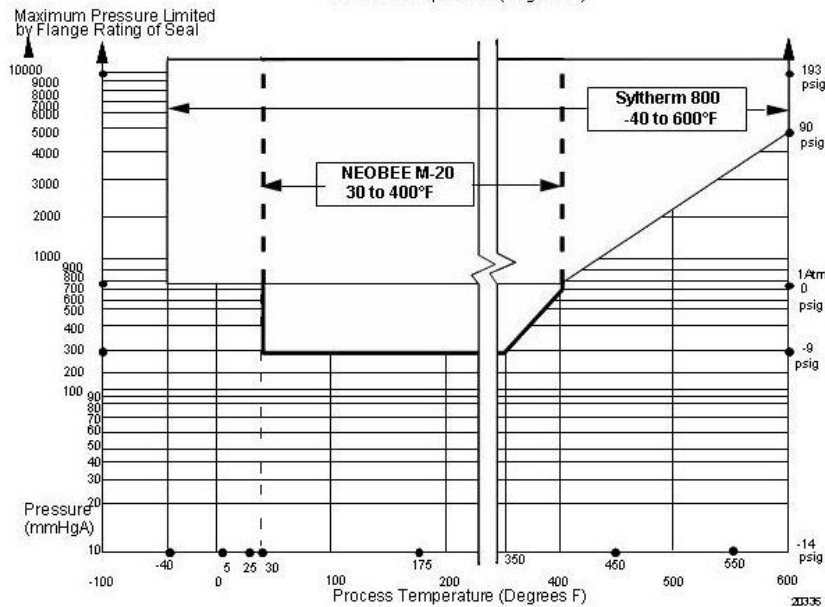
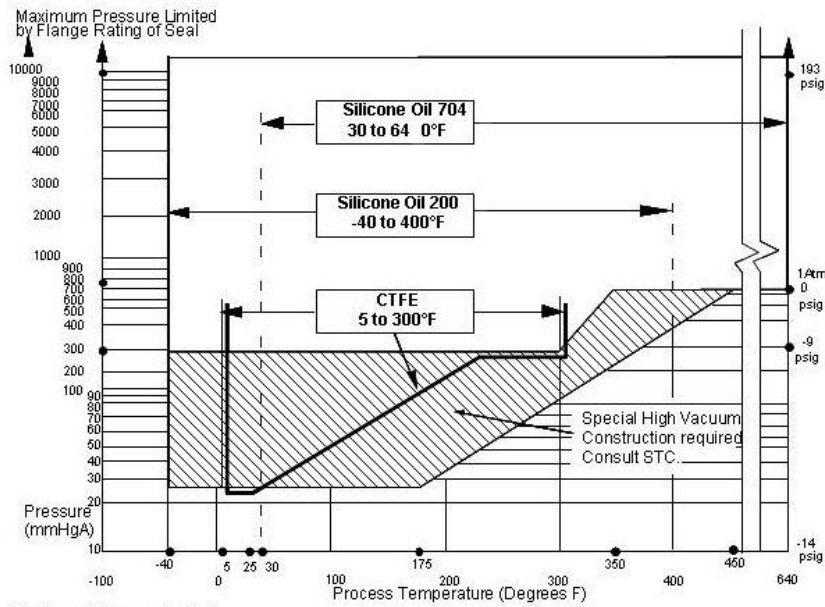

Figure 4 - STR700 Remote Seals operable limits for pressure vs. temperature

### Performance Under Rated Conditions – All Models

Parameter	Description									
<b>Analog Output Digital Communications:</b>	Two-wire, 4 to 20 mA (HART & DE Transmitters only) Honeywell DE, HART protocol All transmitters, irrespective of protocol have polarity insensitive connection.									
<b>HART &amp; DE Output Failure Modes</b> (NAMUR for DE Units requires selecting display and configuration buttons or factory configuration)	<table border="0"> <thead> <tr> <th></th> <th>Honeywell Standard</th> <th>NAMUR NE 43 Compliance</th> </tr> </thead> <tbody> <tr> <td><b>Normal Limits:</b></td> <td>3.8 – 20.8 mA</td> <td>3.8 – 20.5 mA</td> </tr> <tr> <td><b>Failure Mode:</b></td> <td>≤ 3.6 mA and ≥ 21.0 mA</td> <td>≤ 3.6 mA and ≥ 21.0 mA</td> </tr> </tbody> </table>		Honeywell Standard	NAMUR NE 43 Compliance	<b>Normal Limits:</b>	3.8 – 20.8 mA	3.8 – 20.5 mA	<b>Failure Mode:</b>	≤ 3.6 mA and ≥ 21.0 mA	≤ 3.6 mA and ≥ 21.0 mA
	Honeywell Standard	NAMUR NE 43 Compliance								
<b>Normal Limits:</b>	3.8 – 20.8 mA	3.8 – 20.5 mA								
<b>Failure Mode:</b>	≤ 3.6 mA and ≥ 21.0 mA	≤ 3.6 mA and ≥ 21.0 mA								
<b>Supply Voltage Effect</b>	0.005% span per volt									
<b>Transmitter Turn on Time (includes power up &amp; test algorithms)</b>	HART or DE: 2.5 seconds									
<b>Damping Time Constant</b>	<b>HART:</b> Adjustable from 0 to 32 seconds in 0.1 increments. <b>Default:</b> 0.50 seconds <b>DE:</b> Discrete values 0, .16, .32, .48, 1, 2, 4, 8, 16, 32 seconds. <b>Default:</b> 0.48 seconds									
<b>Electromagnetic Compatibility</b>	IEC 61326-3-1									
<b>Lightning Protection Option</b>	<b>Leakage Current:</b> 10uA max @ 42.4VDC 93C <b>Impulse rating:</b> 8/20us 5000A (>10 strikes) 10000A (1 strike min.) 10/1000us 200A (> 300 strikes)									

### Materials Specifications (see model selection guide for availability/restrictions with various models)

Parameter	Description
<b>Process Interface</b>	See Model Selection Guide for Material Options for desired seal type.
<b>Seal Barrier Diaphragm</b>	316L Stainless Steel, Monel®, Hastelloy® C, Tantalum
<b>Seal Gasket Materials</b>	Viton, Graphite, Teflon®
<b>Mounting Bracket</b>	Carbon Steel (Zinc-Chromate plated) or 304 Stainless Steel or 316 Stainless Steel.
<b>Fill Fluid (Meter Body)</b>	Silicone 200 S.G. @ 25°C = 0.94
	CTFE (Chlorotrifluoroethylene) S.G. @ 25°C = 1.89
	Silicone 704 S.G. @ 25°C = 1.07
	NEOBEE M-20® S.G. @ 25°C = 0.93
<b>Fill Fluid (Secondary)</b>	Silicone 200 S.G. @ 25°C = 0.94
	CTFE (Chlorotrifluoroethylene) S.G. @ 25°C = 1.89
	Silicone 704 S.G. @ 25°C = 1.07
	Syltherm 800® S.G. @ 25°C = 0.90
	NEOBEE M-20® S.G. @ 25°C = 0.93
<b>Electronic Housing</b>	Pure Polyester Powder Coated Low Copper (<0.4%) – Aluminum. Meets Type 4X / IP66 / IP67. Dual certified SS316/316L housing is optional. Cover O ring material: Silicone.
<b>Capillary Tubing</b>	<b>Material:</b> Armored Stainless Steel or PVC Coated Armored Stainless Steel. <b>Length:</b> 5, 10, 15, 20, 25, and 35 feet (1.5, 3, 4.6, 6.1, 7.5, and 10.7 meters). A 2-inch (51 millimeter) S.S. close-coupled nipple is also available. See Model Selection Guide. Refer to Figure 5 for guide to maximum capillary length vs. diaphragm diameter. <b>Note:</b> The minimum span is the higher of the value from the table above or the value defined under the Performance Conditions for the range transmitter.
<b>Wiring</b>	Accepts up to 16 AWG (1.5 mm diameter)
<b>Mounting</b>	See Figure 6 - 8
<b>Dimensions</b>	<b>Transmitter:</b> See Figures 7a and 7b. <b>Seal:</b> See Figure 8 through Figure 15
<b>Net Weight</b>	<b>Transmitter:</b> 8.3 pounds (3.8 Kg). With Aluminum Housing. Total weight is dependent on the seal.

**NOTE:** Pressure transmitters that are part of safety equipment for the protection of piping (systems) or vessel(s) from exceeding allowable pressure limits, (equipment with safety functions in accordance with Pressure Equipment Directive 97/23/EC article 1, 2.1.3), require separate examination.

**Minimum recommended span for STR73D Transmitter with two Seals**

Diaphragm Size (Inch)	Capillary Length (Feet)						Maximum Capillary Length (Feet)
	5	10	15	20	25	35	
1.9	15 psi	20 psi	25 psi	-	-	-	15
2.4	5.4 psi	7.2 psi	9.0 psi	10.8 psi	12.6 psi	14.4 psi	35
2.9	1.8 psi	2.7 psi	3.6 psi	4.5 psi	5.4 psi	7.2 psi	35
3.5	0.9 psi	0.9 psi	0.9 psi	1.0 psi	1.2 psi	1.4 psi	35
4.1	0.9 psi	0.9 psi	0.9 psi	0.9 psi	0.9 psi	1.1 psi	35

**Minimum recommended span for STR74G and STR73D Transmitter with one Remote Seal**

Diaphragm Size (Inch)	Direct Mount	Capillary Length (Feet)						Maximum Capillary Length (Feet)
		5	10	15	20	25	35	
1.9	25 psi	30 psi	40 psi	50 psi	-	-	-	15
2.4	10 psi	15 psi	20 psi	25 psi	30 psi	35 psi	50 psi	35
2.9	8 psi	9 psi	10 psi	11 psi	12 psi	13 psi	15 psi	35
3.5	2 psi	2 psi	3 psi	4 psi	5 psi	6 psi	8 psi	35
4.1	0.9 psi	0.9 psi	1 psi	2 psi	3 psi	3.5 psi	5 psi	35

**Note:** The minimum span is the higher of the higher of the value from the table above or the value defined under the Performance Conditions for the range transmitter.

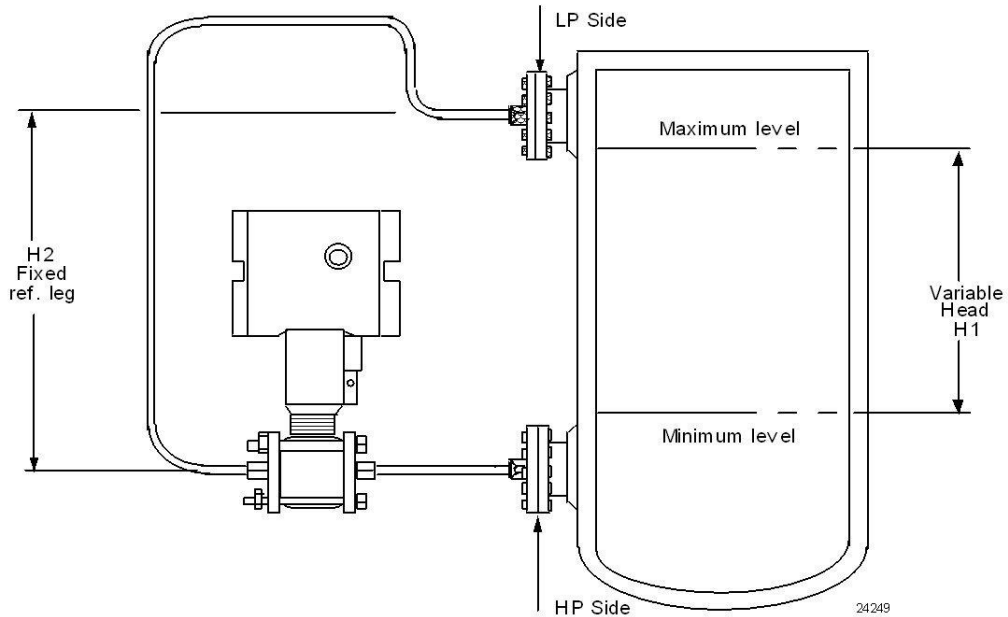

NOTE: Lower flange seal should not be mounted over 22 feet below or above the transmitter for silicone fill fluid (11 feet for CTFE fill fluid) with tank at one atmosphere. The combination of tank vacuum and high pressure capillary head effect should not exceed 9 psi vacuum (300 mmHg absolute).

Consult Honeywell for installation of STR73D.

**Figure 5– Typical Maximum capillary length and diaphragm size chart**

Reference Dimensions Horizontal Mounting

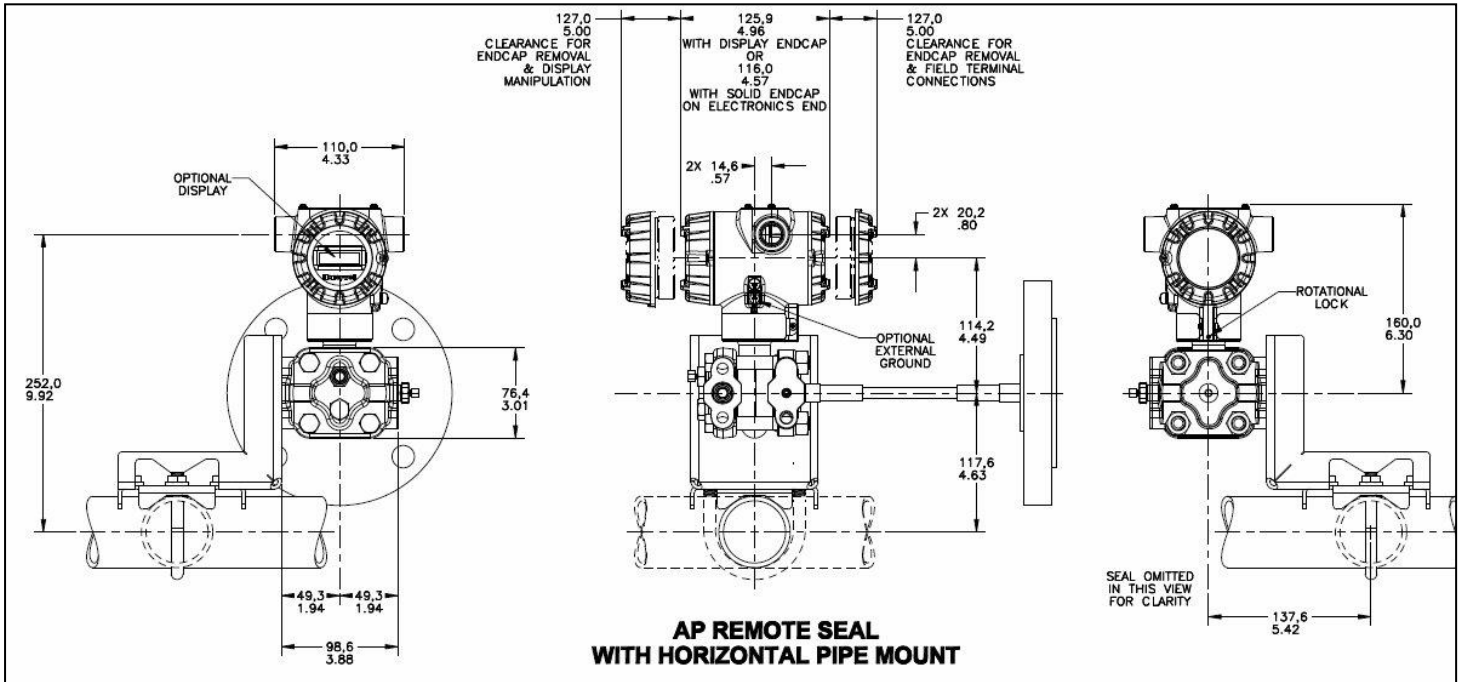
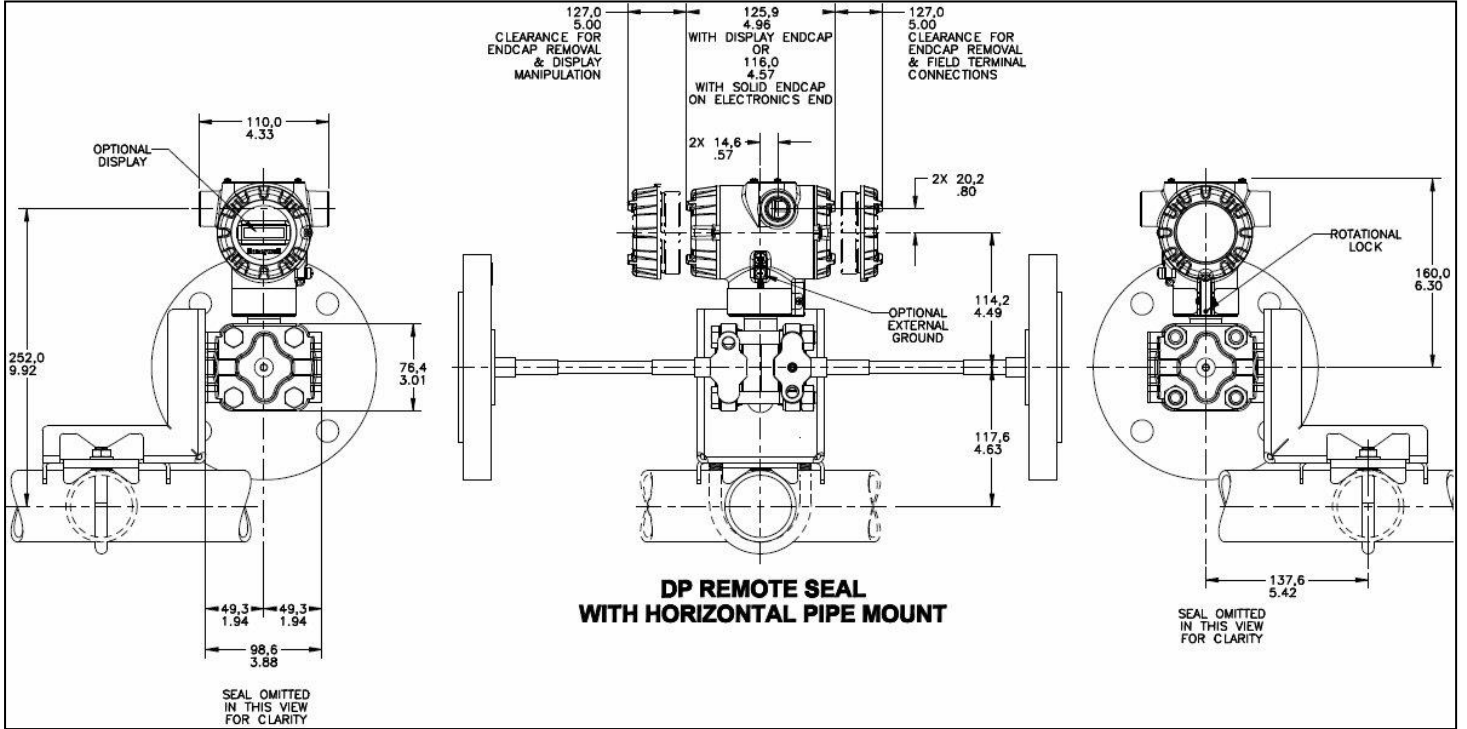

Figure 6 - STR700 transmitter with remote diaphragm seals shown mounted on a tank

**Reference Dimensions Horizontal Mounting (cont'd)**

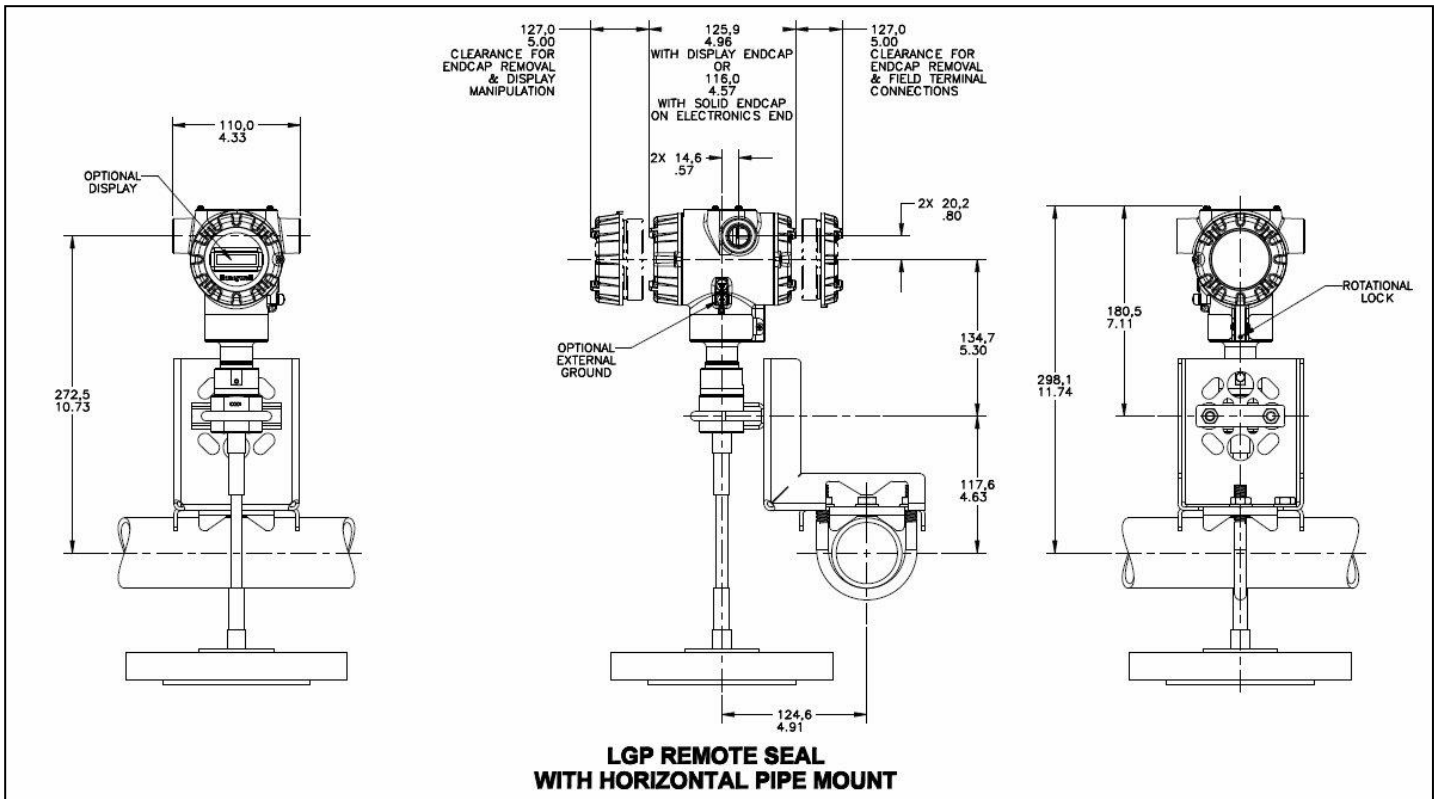
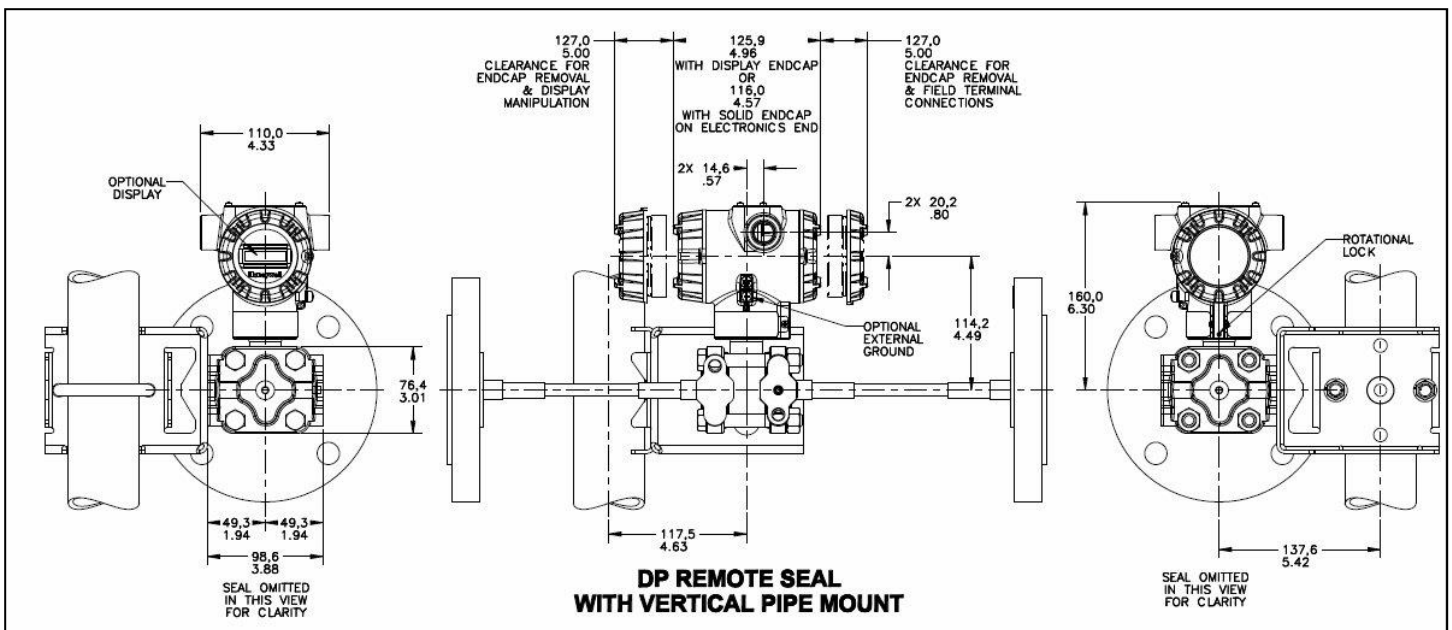

Figure 7 — Approximate horizontal mounting dimensions for Remote Seal Transmitter

**Reference Dimensions Vertical Mounting**



### Reference Dimensions Vertical Mounting (cont'd)

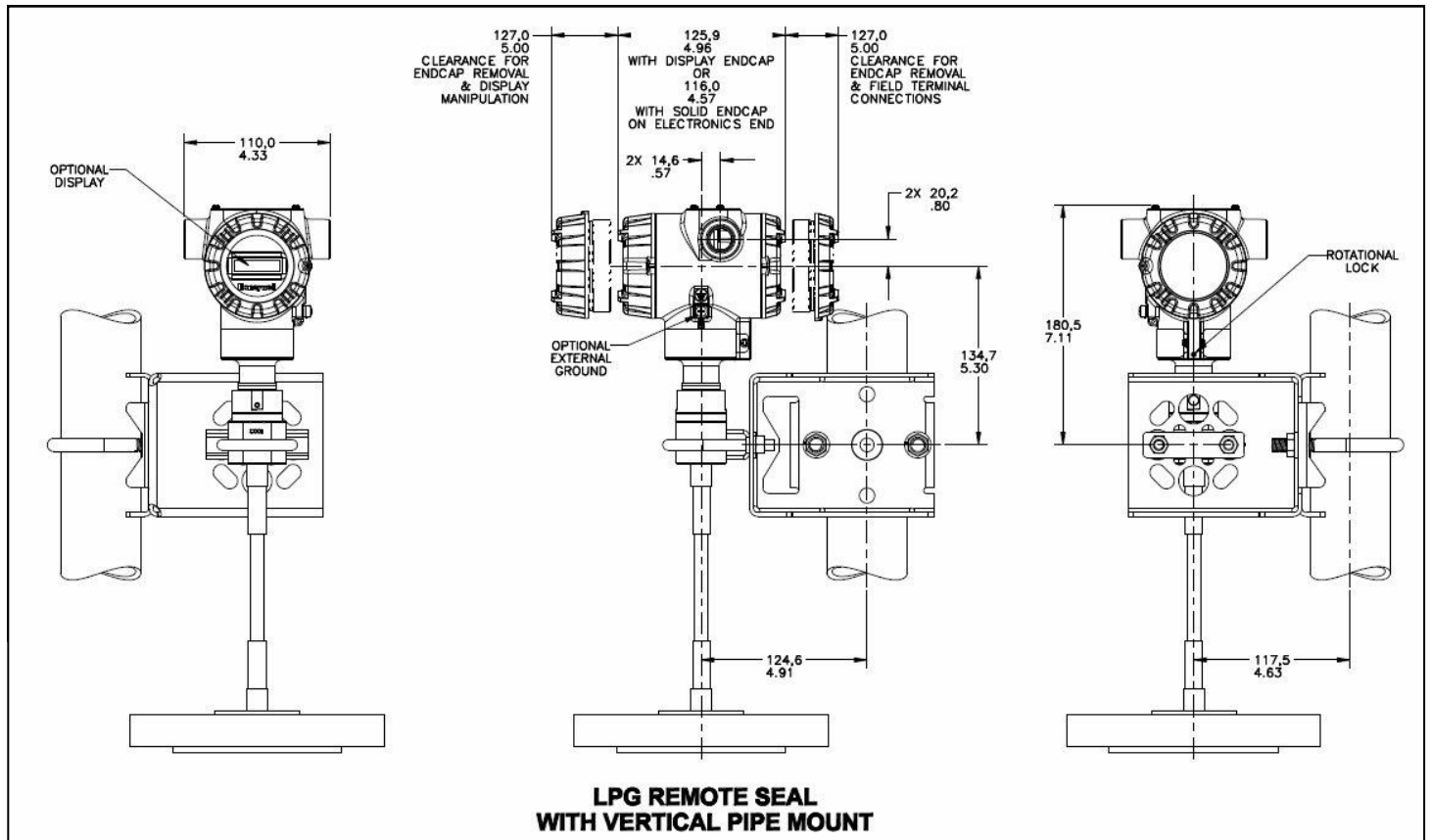
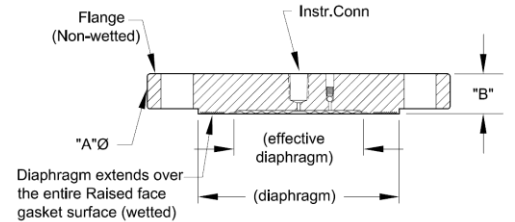

Figure 8 — Approximate vertical mounting dimensions for Remote Seal Transmitter

Reference Dimensions (cont'd)

Flush Flanged Seal Dimensions

Type	ANSI/DIN Rating	Flange Material	Wetted Materials		Construction See figure	↔ ↑	
			Diaphragm	Body		A	B
Flush Flanged Seal	3" Class 150#	CS	SS	SS	D	7.5	2.06
			Hastelloy C	SS	C		
		SS	SS	N/A	B	7.50	0.94
				Hastelloy C	SS		
		CS	SS	SS	D	8.25	2.25
				Hastelloy C	SS		
		SS	SS	N/A	B	8.25	1.12
				Hastelloy C	SS		
		CS	SS	SS	D	8.25	2.25
				Hastelloy C	SS		
		SS	SS	N/A	B	8.25	1.5
				Hastelloy C	SS		
	CS	SS	SS	D	7.87	1.95	
			Hastelloy C	SS			C
	SS	SS	N/A	B	7.87	0.94	
			Hastelloy C	SS			A
	CS	SS	SS	D	7.87	1.95	
			Hastelloy C	SS			C



Configuration "HS"

Figure A

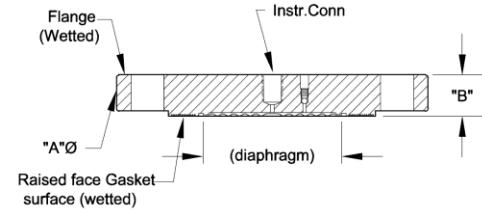

Configuration "HT"

Figure B

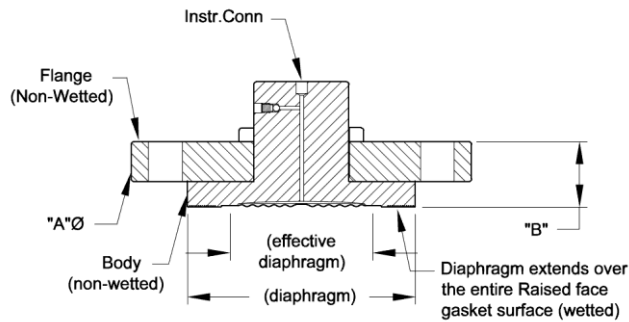

Configuration "IS"

Figure C

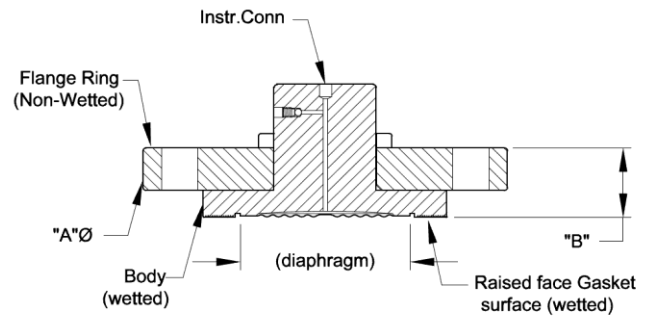

Configuration "IT"

Figure D

Figure 9 - Seal Dimensions (Flush Flanged)

Reference Dimensions (cont'd)

Flush Flanged Seal with Lower

Type	ANSI/DIN Rating	Size	Dimension	2.4" Diaphragm (52 mm effective)	2.9" Diaphragm (64 mm effective)	4.1" Diaphragm (35 mm effective)	
Flush Flanged Seal with Lower	Class 150#	1/2"	A	3.74	N/A	5.91	
			B0	1.55		2.21	
			B1	1.55		2.21	
			B2	1.70		2.21	
		1"	A	4.33		5.91	
			B0	1.33		2.05	
			B1	1.33		2.05	
			B2	1.48		2.05	
		1-1/2"	A	5.00		4.92	5.91
			B0	1.33		2.33	1.97
			B1	1.33		2.33	1.97
			B2	1.48		2.83	1.97
	2"	A	N/A	6.00	5.91		
		B0		2.36	1.89		
		B1		2.36	1.89		
		B2		2.86	1.89		
	3"	A	N/A	N/A	7.50		
		B0			2.55		
		B1			2.55		
		B2			3.05		
	Class 300#	1/2"	A	3.74	N/A	5.91	
			B0	1.55		2.21	
			B1	1.55		2.21	
			B2	1.70		2.21	
1"		A	4.92	5.91			
		B0	1.33	2.05			
		B1	1.33	2.05			
		B2	1.48	2.05			
1-1/2"		A	6.12	6.10		6.10	
		B0	1.48	2.45		2.21	
		B1	1.48	2.45		2.21	
		B2	1.63	2.95		2.21	
2"	A	N/A	N/A	6.50			
	B0			2.49			
	B1			2.49			
	B2			2.99			
3"	A	N/A	N/A	8.25			
	B0			2.74			
	B1			2.74			
	B2			3.24			
Class 600#	1/2"	A	3.74	N/A	5.91		
		B0	1.71		2.36		
		B1	1.71		2.35		
		B2	1.87		2.35		
	1"	A	4.88		5.91		
		B0	2.36		2.26		
		B1	2.36		2.26		
		B2	2.86		2.26		
	1-1/2"	A	6.12		6.12	6.10	
		B0	1.33		2.55	2.21	
		B1	1.33		2.55	2.21	
		B2	1.48		3.05	2.21	
2"	A	N/A	N/A	6.50			
	B0			2.68			
	B1			2.68			
	B2			3.18			
3"	A	N/A	N/A	8.25			
	B0			2.93			
	B1			2.93			
	B2			3.43			

B0 Without Flush  
 B1 B Dimension with 1/4 NPT Flushing Connection  
 B2 B Dimension with 1/2 NPT Flushing Connection

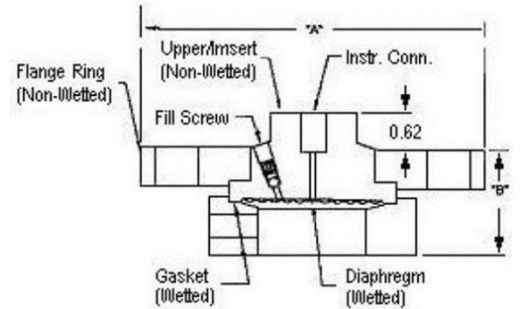

Flush Flanged Seal with Lower

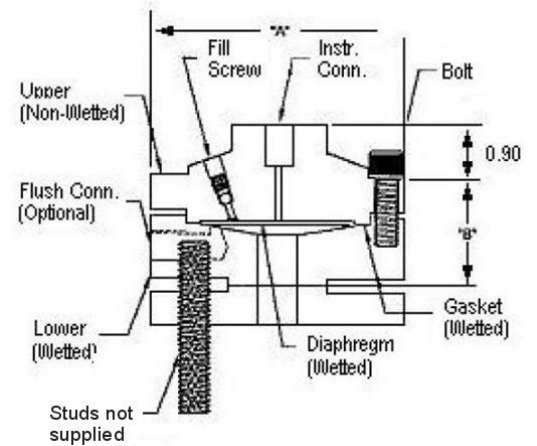

Flush Flanged Seal with Lower

Note: 0.90 dimension is 0.70 for 4.1" Dia Diaphragm

Figure 10- Seal Dimension (Flush Flanged)

**Reference Dimensions (cont'd)**

**Flanged Seal with Extended Diaphragm**

Type	ANSI/DIN Rating	Dimension	2.8" Diaphragm Dia. (in.)	3.5" Diaphragm Dia. (in.)
Flanged Seal with Extended Diaphragm	3" Class 150#	A	7.50	-
		B	0.94	-
		C	2.80	-
	3" Class 300#	A	8.25	-
		B	1.12	-
		C	2.80	-
	DIN DN80-PN40	A	7.87	-
		B	0.94	-
		C	2.80	-
	4" Class 150#	A	-	9.00
		B	-	0.94
		C	-	3.70
4" Class 300#	A	-	10.00	
	B	-	1.25	
	C	-	3.70	
DIN DN100-PN40	A	-	9.25	
	B	-	0.94	
	C	-	3.70	

Designed to meet with schedule 40 pipe

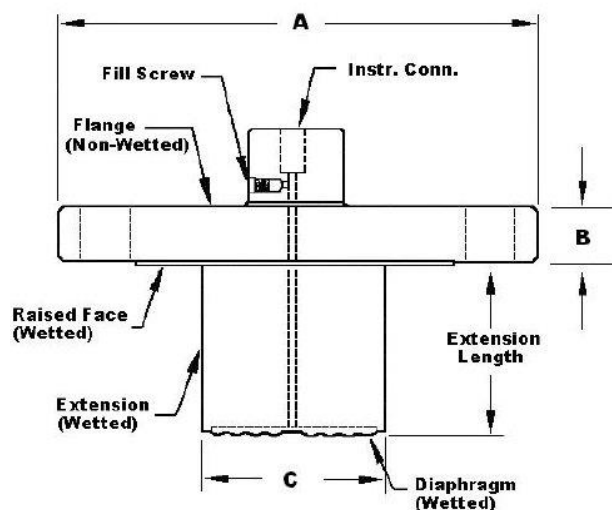

**Figure 11 — Seal Dimensions (Extended Diaphragms)**

**Pancake Seal**

Type	ANSI/DIN	Dimension	3.5" Diaph. (in.)
Pancake Seal	Class 150#, 300#, 600# DN80-PN40	A	5.00
		B	1.08

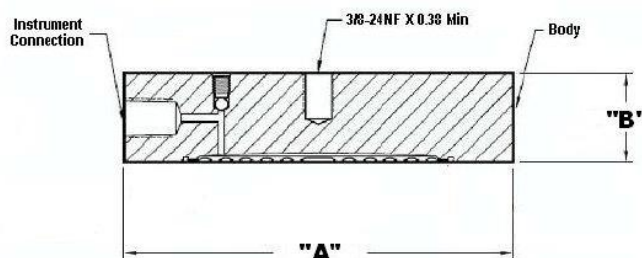

**Figure 12 — Seal Dimensions (Pancake)**

**Chemical Tee "Taylor Wedge" Seal**

Type	Size	Dimension	3.5" Diaph. (in.)
Chemical Tee "Taylor Wedge" Seal	750 psi	A	5.00
		B	0.50

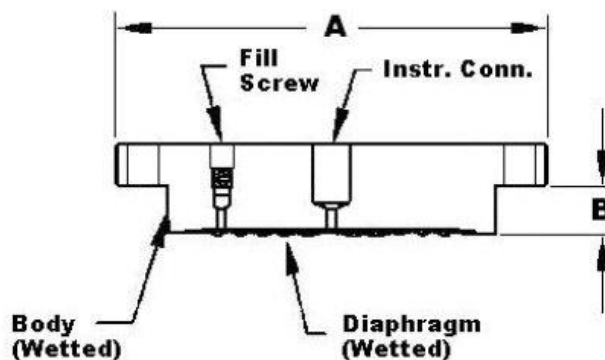
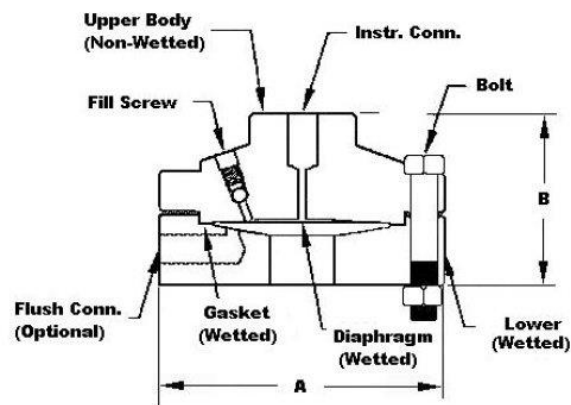

**Figure 13 — Seal Dimensions (Chemical TEE "Taylor Wedge" Seals)**

**Seal with Threaded Process Connection**

Type	Size	Dimensions	2.4" Diaphragm (52 mm effective)	4.1" Diaphragm (35 mm effective)
Threaded Process Conn. Seal	1/4" and 1/2"	A	3.74	5.90
		B0	2.20	2.50
		B1	2.20	2.50
		B2	3.50	2.75
	3/4" and 1"	A	3.74	5.90
		B0	2.40	2.80
		B1	2.40	2.80
		B2	3.70	3.05

B0 Without Flush  
 B1 B Dimension with 1/4 NPT Flushing Connection  
 B2 B Dimension with 1/2 NPT Flushing Connection



**Figure 14— Seal Dimensions (Threaded Process Connection Seals)**

**Sanitary Seal**

Type	Size	Dimension	1.9" Diaphragm Dia. (in.)	2.4" Diaphragm Dia. (in.)	2.9" Diaphragm Dia. (in.)	4.1" Diaphragm Dia. (in.)
Sanitary Seal	2"	A	2.50	-	-	-
		B	1.42	-	-	-
	2- 1/2"	A	-	3.00	-	-
		B	-	1.28	-	-
	3"	A	-	-	3.57	-
		B	-	-	1.38	-
	4"	A	-	-	-	4.68
		B	-	-	-	1.60

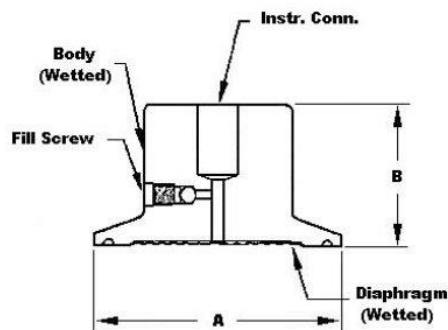

**Figure 15— Seal Dimensions (Sanitary Seals)**

**Saddle Seal**

Type	Size	Dimensions	2.4" Diaphragm (52 mm effective)
Saddle Seal	3"	A B	3.50 1.90
	4" or larger	A B	3.50 1.90

Note: Specify 6 or 8 bolt pattern

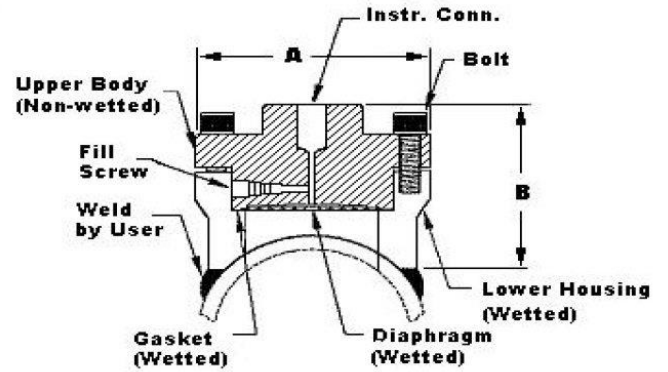

Figure 16— Seal Dimensions (3" Saddle Seal)

**Calibration Ring**

Type	Size	Rating	Dimension	1/4 NPT	1/2 NPT
Calibration Ring	3"	150# / 800#	A	5.00	5.00
			B	1.00	1.50
			C	3.00	3.00

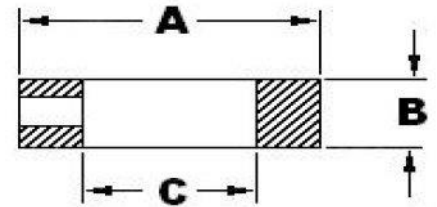

Figure 17— Calibration Ring

## Communications Protocols & Diagnostics

### HART Protocol

#### Version:

HART 7

### Honeywell Digitally Enhanced (DE)

DE is a Honeywell proprietary protocol which provides digital communications between Honeywell DE enabled field devices and Hosts.

### Standard Diagnostics

ST 700 top level diagnostics are reported as either critical or non-critical and are readable via the DD/DTM/FDI tools or integral display. All critical diagnostics will appear on the Advanced and Standard integral displays, and some non-critical diagnostics will also appear on the Advanced integral display. Some of the diagnostics are listed below.

#### Critical Diagnostics

- Electronics Module Fault.
- Meter body Memory Corruption.
- Config Data Corruption.
- Electronics Module Diagnostics Failure.
- Meter body Critical Failure.
- Sensor Communication Timeout.

#### Non-Critical Diagnostics









- Electronics Module Fault.
- Display Failure.
- Electronics Module Comm Failure.
- Meter body Excess Correct.
- Sensor Over Temperature.
- Fixed Current Mode.
- PV Out of Range.
- No DAC Compensation.
- Tamper Attempt Alarm.

Refer to the product user manual for comprehensive list of diagnostics and details.

---

## Hazardous Areal Certifications:

MSG CODE	AGENCY	TYPE OF PROTECTION	COMM. OPTION	ELECTRICAL PARAMETERS	AMBIENT TEMP (Ta)
A	FM Approvals™ USA	<b>Explosionproof:</b> Class I, Division 1, Groups A, B, C, D; Dust Ignition Proof: Class II, III, Division 1, Groups E, F, G; T6..T5 Class I, Zone 0/1, AEx db IIC T6..T5 Ga/Gb Class II, Zone 21, AEx tb IIIC T95° Db	All	Note 1	T5: -50 °C to 85°C T6: -50 °C to 65°C
		<b>Intrinsically Safe:</b> Class I, II, III, Division 1, Groups A, B, C, D, E, F, G: T4 Class I, Zone 0, AEx ia IIC T4 Ga FISCO Field Device (Only for FF Option) Ex ia IIC T4 Ga; Ex ic IIC T4 Gc	4-20 mA / DE/ HART	Note 2a	-50 °C to 70°C
		<b>Nonincendive:</b> Class I, Division 2, Groups A, B, C, D locations, T4 Class I, Zone 2, AEx nA IIC T4 Gc	Foundation Fieldbus	Note 2b	-50 °C to 70°C
		<b>Nonincendive:</b> Class I, Division 2, Groups A, B, C, D locations, T4 Class I, Zone 2, AEx nA IIC T4 Gc	4-20 mA / DE/ HART/ Foundation Fieldbus	Note 1	-50 °C to 85°C
		<b>Enclosure:</b> Type 4X/ IP66/ IP67	All	All	-
		<b>STANDARDS:</b> FM Class 3600:2011; FM Class 3610: 2010; FM Class 3611: 2004; FM Class 3615: 2006; FM Class 3616: 2011; FM Class 3810: 2005; ANSI/ISA 60079-0: 2013; ANSI/UL 60079-1: 2015; ANSI/UL 60079-11: 2014; ANSI/ISA 60079-15: 2012; ANSI/UL 60079-26: 2017; ANSI/UL 60079-31: 2015; ANSI/NEMA 250: 2003; ANSI/ IEC 60529: 2004			
B	Canadian Standards Association (CSA) USA and Canada	<b>Explosion Proof:</b> Class I, Division 1, Groups A, B, C, D; Class II, Division 1, Groups E, F, G; Class III, Division 1, T6..T5 Class I Zone 1 AEx db IIC T6..T5 Ga/Gb Ex db IIC T6..T5 Ga/Gb Zone 22 AEx tb IIIC T95° Db Ex tb IIIC T95° Db	All	Note 1	T5: -50°C TO 85°C T6: -50°C TO 65°C
		<b>Intrinsically Safe:</b> Class I, II, III, Division 1, Groups A, B, C, D; Class II, Division 1, Groups E, F, G; Class III, Division 1, T4 Class I Zone 0, AEx ia IIC T4 Ga Class I Zone 2, AEx ic IIC T4 Gc Ex ia IIC T4 Ga Ex ic IIC T4 Gc FISCO Field Device (Only for FF Option) Ex ia IIC T4 Ga; Ex ic IIC T4 Gc	4-20 mA / DE/ HART	Note 2	-50°C TO 70°C
		<b>Nonincendive:</b> Class I, Division 2, Groups A, B, C, D; Class II, Division 2, Groups F, G; Class III, Division 2, T4 Class I Zone 2 AEx nA IIC T4 Gc Ex nA IIC T4 Gc	Foundation Fieldbus	Note 2	-50°C TO 70°C
		<b>Nonincendive:</b> Class I, Division 2, Groups A, B, C, D; Class II, Division 2, Groups F, G; Class III, Division 2, T4 Class I Zone 2 AEx nA IIC T4 Gc Ex nA IIC T4 Gc	4-20 mA / DE/ HART/ Foundation Fieldbus	Note 1	-50°C to 85°C
		<b>Enclosure:</b> Type 4X/ IP66/ IP67	All	All	-

MSG CODE	AGENCY	TYPE OF PROTECTION	COMM. OPTION	ELECTRICAL PARAMETERS	AMBIENT TEMP (Ta)
		<b>STANDARDS:</b> CSA C22.2 No. 0-10; CSA C22.2 No. 94-M91; CSA C22.2 No. 25-1966; CSA C22.2 No. 30-M1986; CSA C22.2 No. 142-M1987; CSA C22.2 No. 157-92; CSA C22.2 No. 213-M1987; CSA-C22.2 No. 60529:05; CSA-C22.2 No. 60079-0:11; CSA-C22.2 No. 60079-1:11; CSA-C22.2 No. 60079-11:11; CSA-C22.2 No. 60079-15:12; CSA-C22.2 No. 60079-31:12; ISA 12.12.01-2010; ISA 60079-0: 2009; ISA 60079-11: 2011; ISA 60079-15: 2009; ISA 60079-26: 2008; ISA-60079-27:2007 (12.02.04)-2006 (R2011); UL 913 Ed. 6; UL 916:1998; ANSI/ISA-12.27.01-2011			
C	ATEX	<b>Flameproof: SIRA 12ATEX2233X</b>  II 1/2 G Ex db IIC T6..T5 Ga/Gb II 2 D Ex tb IIIC T95°C...T120°C Db	All	Note 1	T5: -50°C TO 85°C T6: -50°C TO 65°C
		<b>Intrinsically Safe: SIRA 12ATEX2233X</b>  II 1 G Ex ia IIC T4 Ga II 2 D Ex ia IIIC T125°C Db FISCO Field Device (Only for FF Option) II 1 G Ex ia IIC T4 Ga	4-20 mA / DE/ HART	Note 2	-50°C TO 70°C
		<b>Zone 2, Increase Safety: SIRA 12ATEX4234X</b>  II 3 G Ex ec IIC T4 Gc	4-20 mA / DE/ HART/	Note 1	-50°C TO 85°C
		<b>Zone 2, Intrinsically Safe: SIRA 12ATEX4234X</b>  II 3 G Ex ic IIC T4 Gc FISCO Field Device (Only for FF Option) II 3 G Ex ic IIC T4 Gc	4-20 mA / DE/ HART/ Foundation Fieldbus	Note 2	-50°C TO 85°C
		<b>Enclosure: IP66/ IP67</b>	All	All	-
		<b>STANDARDS:</b> EN 60079-0: 2018; EN 60079-1: 2014; EN 60079-7: 2015+A1: 2018; EN 60079-11: 2012; EN 60079-26: 2015; EN 60079-31: 2014			
	UKEX	<b>Flameproof: CSAE 22UKEX1021X</b>  II 1/2 G Ex db IIC T6..T5 Ga/Gb II 2 D Ex tb IIIC T95°C...T120°C Db	All	Note 1	T5: -50°C TO 85°C T6: -50°C TO 65°C
		<b>Intrinsically Safe: CSAE 22UKEX1021X</b>  II 1 G Ex ia IIC T4 Ga II 2 D Ex ia IIIC T125°C Db FISCO Field Device (Only for FF Option) II 1 G Ex ia IIC T4 Ga	4-20 mA / DE/ HART	Note 2	-50°C TO 70°C
		<b>Zone 2, Increase Safety: CSAE 22UKEX1008X</b>  II 3 G Ex ec IIC T4 Gc	4-20 mA / DE/ HART/	Note 1	-50°C TO 85°C
		<b>Zone 2, Intrinsically Safe: CSAE 22UKEX1008X</b>  II 3 G Ex ic IIC T4 Gc FISCO Field Device (Only for FF Option) II 3 G Ex ic IIC T4 Gc	4-20 mA / DE/ HART/ Foundation Fieldbus	Note 2	-50°C TO 85°C
		<b>Enclosure: IP66/ IP67</b>	All	All	-
		<b>STANDARDS:</b> EN 60079-0: 2018; EN 60079-1: 2014; EN 60079-7: 2015+A1: 2018; EN 60079-11: 2012; EN 60079-26: 2015; EN 60079-31: 2014			

MSG CODE	AGENCY	TYPE OF PROTECTION	COMM. OPTION	ELECTRICAL PARAMETERS	AMBIENT TEMP (Ta)
		<b>STANDARDS:</b> EN 60079-0: 2018; EN 60079-1: 2014; EN 60079-7: 2015+A1: 2018; EN 60079-11: 2012; EN 60079-26: 2015; EN 60079-31: 2014			
D	IECEX World	<b>Flameproof: IECEX SIR 12.0100X</b> Ex db IIC T6..T5 Ga/Gb Ex tb IIIC T95°C...T120°C Db	All	Note 1	T5: -50°C TO 85°C T6: -50°C TO 65°C
		<b>Intrinsically Safe: IECEX SIR 12.0100X</b> Ex ia IIC T4 Ga Ex ia IIIC T125°C FISCO Field Device (Only for FF Option) Ex ia IIC T4 Ga; Ex ic IIC T4 Gc	4-20 mA / DE/ HART	Note 2	-50°C TO 70°C
			Foundation Fieldbus	Note 2	-50°C TO 70°C
		<b>Zone 2, Increase Safety: IECEX SIR 12.0100X</b> Ex ec IIC T4 Gc	4-20 mA / DE/ HART/ Foundation Fieldbus	Note 1	-50°C TO 85°C
		<b>Zone 2, Intrinsically Safe: IECEX SIR 12.0100X</b> Ex ic IIC T4 Gc FISCO Field Device (Only for FF Option) Ex ic IIC T4 Gc	4-20 mA / DE/ HART/ Foundation Fieldbus	Note 2	-50°C TO 85°C
		<b>Enclosure:</b> IP66/ IP67	All	All	-
<b>STANDARDS:</b> IEC 60079-0: 2017; IEC 60079-1: 2014; IEC 60079-7: 2017; IEC 60079-11: 2011; IEC 60079-26: 2014; IEC 60079-31: 2013					

E	SAEx South Africa	<b>Flameproof :</b> Ex d IIC T6...T5 Ga/Gb Ex tb IIIC T95°C...T120°C Db	All	Note 1	T5: -50°C TO 85°C T6: -50°C TO 65°C
		<b>Intrinsically Safe:</b> Ex ia IIC Ga T4 FISCO Field Device (Only for FF Option) Ex ia IIC T4 Ga; Ex ic IIC T4 Gc	4-20 mA / DE/ HART	Note 2	-50°C TO 70°C
			Foundation Fieldbus	Note 2	-50°C TO 70°C
		<b>Zone 2, Increase Safety:</b> II 3 G Ex ec IIC T4 Gc	4-20 mA / DE/ HART/ Foundation Fieldbus	Note 1	-50°C TO 85°C
		<b>Zone 2, Intrinsically Safe:</b> Ex ic IIC T4 Gc FISCO Field Device (Only for FF Option) Ex ic IIC T4 Gc	4-20 mA / DE/ HART/ Foundation Fieldbus	Note 2	-50°C TO 85°C
<b>Enclosure:</b> IP66/ IP67		All	All	-	
F	INMETRO Brazil	<b>Flameproof:</b> Ex db IIC T6..T5 Ga/Gb Ex tb IIIC T95°C...T120°C Db	All	Note 1	T5: -50°C TO 85°C T6: -50°C TO 65°C
		<b>Intrinsically Safe:</b> Ex ia IIC T4 Ga  FISCO Field Device (Only for FF Option) Ex ia IIC T4 Ga; Ex ic IIC T4 Gc	4-20 mA / DE/ HART	Note 2a	-50°C TO 70°C
			Foundation Fieldbus	Note 2b	-50°C TO 70°C
		<b>Zone 2, Increase Safety:</b> II 3 G Ex ec IIC T4 Gc	4-20 mA / DE/ HART/ Foundation Fieldbus	Note 1	-50°C TO 85°C
		<b>Zone 2, Intrinsically Safe:</b> Ex ic IIC T4 Gc FISCO Field Device (Only for FF Option) Ex ic IIC T4 Gc	4-20 mA / DE/ HART/ Foundation Fieldbus	Note 2	-50°C TO 85°C
		<b>Enclosure :</b> IP 66/67		All	All
G	NEPSI CHINA	<b>Flameproof:</b> Ex db IIC T6..T5 Ga/Gb Ex tb IIIC T 95°C Db	All	Note 1	T5: -50°C TO 85°C T6: -50°C TO 65°C
		<b>Intrinsically Safe:</b> Ex ia IIC T4 Ga FISCO Field Device (Only for FF Option) Ex ia IIC T4 Ga; Ex ic IIC T4 Gc	4-20 mA / DE/ HART	Note 2	-50°C TO 70°C
			Foundation Fieldbus	Note 2	-50°C TO 70°C
		<b>Zone 2, Increase Safety:</b> II 3 G Ex ec IIC T4 Gc	4-20 mA / DE/ HART/ Foundation Fieldbus	Note 1	-50°C TO 85°C
		<b>Zone 2, Intrinsically Safe:</b> Ex ic IIC T4 Gc FISCO Field Device (Only for FF Option) Ex ic IIC T4 Gc	4-20 mA / DE/ HART/ Foundation Fieldbus	Note 2	-50°C TO 85°C
<b>Enclosure :</b> IP 66/67		All	All	-	
H	KOSHA	<b>Flameproof :</b>	All	Note 1	T4: -50°C TO 85°C

	<b>Korea</b>	Ex d IIC T4, T5, T6 Ex tD A21 IP66/IP67 T95°C...T120°C			T5: -50°C TO 85°C T6: -50°C TO 65°C
		<b>Intrinsically Safe:</b> Ex ia IIC T4	4-20 mA / DE/ HART	Note 2	Ta= -50 °C to 70°C
			Foundation Fieldbus	Note 2	Ta= -50 °C to 70°C
		<b>Enclosure:</b> IP66/ IP67	All	All	-
<b>I</b>	<b>EAC Russia, Belarus and Kazakhstan</b>	<b>Flameproof:</b> Ga/Gb Ex d IIC T6..T5 Ex tb IIIC Db T 85°C	All	Note 1	T5: -50°C TO 85°C T6: -50°C TO 65°C
		<b>Intrinsically Safe:</b> Ga Ex ia IIC T4 X FISCO Field Device (Only for FF Option) Ga Ex ia IIC T4 X	4-20 mA / DE/ HART	Note 2	-50°C TO 70°C
			Foundation Fieldbus	Note 2	-50°C TO 70°C
		<b>Zone 2, Non Sparking:</b> 2 Ex nA IIC T4 Gc X	4-20 mA / DE/ HART/ Foundation Fieldbus	Note 1	-50°C TO 85°C
		<b>Zone 2, Intrinsically Safe:</b> Ga Ex ic IIC T4 X FISCO Field Device (Only for FF Option) 2 Ex ic IIC T4 Gc X	4-20 mA / DE/ HART/ Foundation Fieldbus	Note 2	-50°C TO 85°C
			<b>Enclosure :</b> IP 66/67	All	All
<b>J</b>	<b>CCoE INDIA</b>	<b>Flameproof:</b> Ex d IIC T6..T5 Ga/Gb	All	Note 1	T5: -50°C TO 85°C T6: -50°C TO 65°C
		<b>Intrinsically Safe:</b> Ex ia IIC T4 Ga FISCO Field Device (Only for FF Option) Ex ia IIC T4 Ga; Ex ic IIC T4 Gc	4-20 mA / DE/ HART	Note 2	-50°C TO 70°C
			Foundation Fieldbus	Note 2	-50°C TO 70°C
		<b>Non Sparking</b> Ex nA IIC T4 Gc	4-20 mA / DE/ HART/ Foundation Fieldbus	Note 1	-50°C TO 85°C
		<b>Enclosure:</b> IP66/ IP67	All	All	-
<b>K</b>	<b>UATR UKRAINE</b>	<b>Flameproof:</b> II 1/2 G Ex db IIC T6..T5 Ga/Gb II 2 D Ex tb IIIC T95°C...T120°C Db	All	Note 1	T5: -50°C TO 85°C T6: -50°C TO 65°C
		<b>Intrinsically Safe:</b> II 1 G Ex ia IIC T4 Ga FISCO Field Device (Only for FF Option) II 1 G Ex ia IIC T4 Ga	4-20 mA / DE/ HART	Note 2	-50°C TO 70°C
			Foundation Fieldbus	Note 2	-50°C TO 70°C
		<b>Enclosure:</b> IP66/ IP67	All	All	-



## Application Data

### Liquid Level: Closed Tank

Determine the minimum and maximum pressure differentials to be measured (Figure 18).

$$\begin{aligned} P_{\text{Min}} &= (SG_p \times a) - (SG_f \times d) \\ &= \text{LRV when HP at bottom of tank} \\ &= -\text{URV when LP at bottom of tank} \end{aligned}$$

$$\begin{aligned} P_{\text{Max}} &= (SG_p \times b) - (SG_f \times d) \\ &= \text{URV when HP at bottom of tank} \\ &= -\text{LRV when LP at bottom of tank} \end{aligned}$$

Where:

minimum level at 4mA  
maximum level at 20 mA

a = distance between bottom tap and minimum level

b = distance between bottom tap and maximum level

d = distance between taps

$SG_f$  = Specific Gravity of capillary fill fluid (See Page 6 "Material Specifications" for values.)

$SG_p$  = Specific Gravity of process fluid

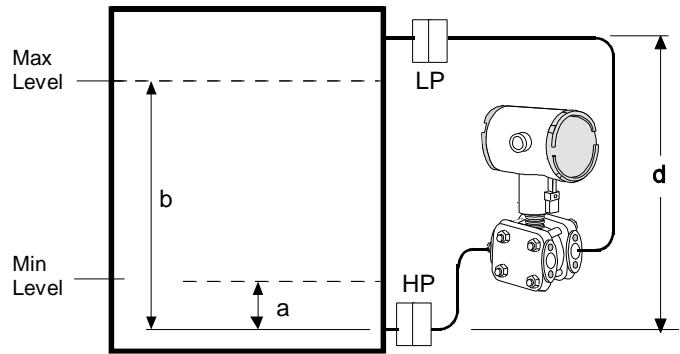

Transmitter above datum

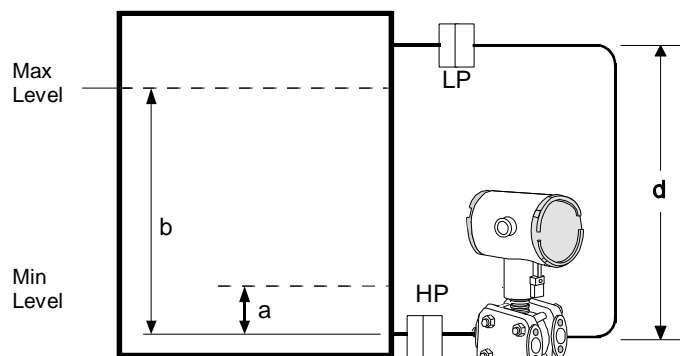

Transmitter at datum

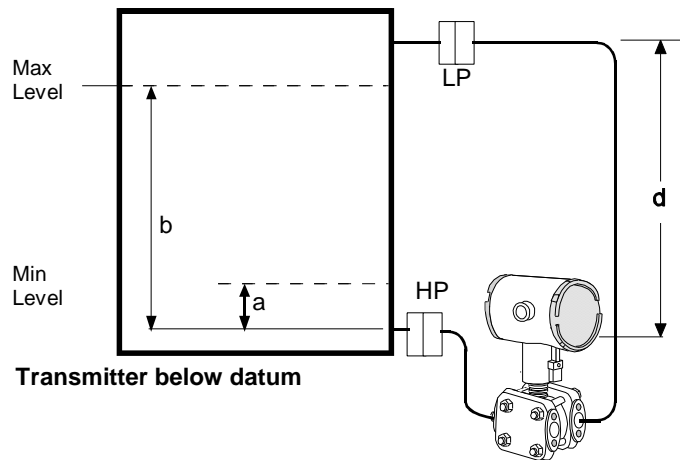

Transmitter below datum

24253

Figure 18- Closed tank liquid level measurement distance

## Application Data (Cont'd)

### Density or Interface\*

Calculate the minimum and maximum pressure differentials to be measured (Figure 19).

$$P_{\min} = (SG_{\min} - SG_f) \times (d);$$

minimum density, 4mA output

$$P_{\max} = (SG_{\max} - SG_f) \times (d);$$

maximum density, 20mA output

Where:

d = distance between the taps

SG<sub>max</sub> = maximum Specific Gravity

SG<sub>min</sub> = minimum Specific Gravity

SG<sub>f</sub> = Specific Gravity of capillary fill fluid (See Page 6 "Material Specifications" for values.)

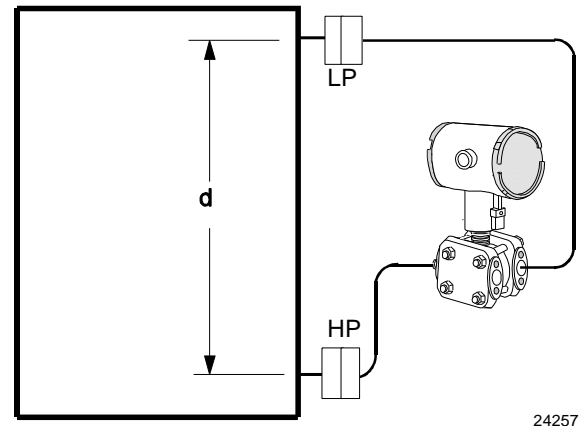

**Figure 19- Density, direct acting transmitter configuration**

## Seal Configurations



**Figure 20—Flush Flange Seals**

Flush Flange Seals can be used with differential, gauge and absolute pressure transmitters and are available with 3" ANSI Class 150, ANSI Class 300 and DIN DN80-PN40 process connections. Flush flange seals can also be provided with Lowers. Lowers are essentially calibration rings, which allow flushing connections if needed.



**Figure 21 — Flange Seal with Extended Diaphragm**

Flange Seal with Extended Diaphragm can be used with differential, gauge and absolute pressure transmitters and are available with 3" and 4" ANSI Class 150, ANSI Class

300, DIN DN80-PN40 and DIN DN100-PN40 process connections. 2", 4" and 6" extension lengths are available



**Figure 22—Pancake Seals**

Pancake Seals can be used with differential, gauge and absolute pressure transmitters and are available with 3" ANSI Class 150, 300 and 600 process connections.



**Figure 23— Chemical Tee "Taylor" Wedge**

Chemical Tee “Taylor” Wedge can be used with differential pressure transmitters and are available with Taylor Wedge 5” O.D. process connection.

### Seal Configurations (cont'd)



**Figure 24— Seals with Threaded Process Connections**

Seals with Threaded Process Connections can be used with differential, gauge and absolute pressure transmitters and are available with ½”, ¾” and 1” NPT Female process connections.



**Figure 25 — Sanitary Seals**

Sanitary Seals can be used with differential, gauge and absolute pressure transmitters and are available with 3” and 4” Tri-Clover-Tri-Clamp process connections.



**Figure 26— Saddle Seals**

Saddle Seals can be used with differential, gauge and absolute pressure transmitters and are available with 3” and 4” (6 bolt or 8 bolt designs) process connections.



**Figure 27 — Calibration Rings**

Calibration Rings are available with Flush Flange Seals and Pancake Seals. Flushing ports (¼” or ½”) are available with calibration rings.



**Figure 28 — Stainless Steel Armor and PVC Coated Stainless Steel Armor Capillaries**

Stainless Steel Armor and PVC Coated Stainless Steel Armor Capillaries are available with Honeywell Remote Seal Solutions.



**Figure 29 — 2” Stainless Steel Nipples**  
2” Stainless Steel Nipples are available for Close-Coupled remote seal solutions



**Figure 30 — Welded Meter Body for All-Welded Remote Seal Solution**

Welded Meter Body for All-Welded Remote Seal Solution. The welded ST 700 meter body is an important part of an All-Welded Remote Seal Solution, which is commonly used in Vacuum applications.

**Model Selection Guide**

Model Selection Guides are subject to change and are inserted into the specifications as guidance only.



Section 13  
Page: STR7-1

**Model STR700  
(DP, GP) Remote Seals**

Honeywell Proprietary

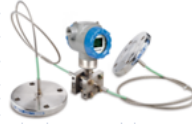

Model Selection Guide  
34-ST-16-104 Issue No 36

**Instructions**

- Select the desired Key Number. The arrow to the right marks the selection available.
- Make selections from each Table (I, II and IX) using the column below the proper arrow.
- A (●) denotes unrestricted availability. A letter denotes restricted availability.
- Restrictions follow Table IX.

Key Number STR7 \_ \_ - I - II - III - IV - V - VI - VII - VIII + IX 0 0 0 0

List Price equals the sum of all selections made.

KEY NUMBER	URL	LRL	Max Span	Min Span	Units	Selection	Availability
Measurement Range	100 (7)	-100 (-7)	100 (7)	0.9 (0.062)	psi (bar)	STR73D	↓
Std Accuracy	500 (35)	-14.7 (-1.0)	500 (35)	5 (0.35)	psi (bar)	STR74G	↓

Note: Remote seal system pressure rating is body rating or seal rating, whichever is less.

TABLE I	Description	Selection				
Meter Body & Capillaries	a. Number of Seals	1 Remote Seal (High Side) 2 Remote Seals 1 Remote Seal (Low Side)	1 _ _ _ _ _ 2 _ _ _ _ _ 3 _ _ _ _ _	• • •	•	
	b. Primary Fill Fluid (Meter body)	Silicone Oil 200 Fluorinated Oil CTFE Silicone Oil 704 NEOBEE® M-20 <sup>11</sup>	_ 1 _ _ _ _ _ 2 _ _ _ _ _ 3 _ _ _ _ _ 4 _ _ _ _	• 2 • •	• 2 • •	
	c. Construction	<b>Non-Wetted Adapter Head Materials</b>				
	In-Line Gauge	316 SS Bonnet 316 SS Bonnet for Close-Couple	316 SS (bolt-on heads)	_ _ A _ _ _		•
			316 SS for Close-Couple	_ _ B _ _ _		3
	Dual Head DP	316 SS with all-welded meter body	316 SS (bolt-on heads)	_ _ C _ _ _	•	
			316 SS for Close-Couple	_ _ D _ _ _	3	
			316 SS with all-welded meter body	_ _ E _ _ _	4	
	d. Bolts and Nuts for Transmitter Heads	None Carbon Steel Bolts and Nuts 316 SS Bolts and Nuts A286 SS (NACE) Bolts and 304 SS (NACE) Nuts B7M (NACE) Bolts and 7M (NACE) Nuts	_ _ _ 0 _ _ _ _ _ C _ _ _ _ _ S _ _ _ _ _ N _ _ _ _ _ B _ _	22 • • • •	•	
	e. Secondary Fill Fluid (capillary & seal)**	No Fill Fluid Silicone Oil 200 Fluorinated Oil CTFE Silicone Oil 704 Neobee® M20 <sup>11</sup> Syltherm® 800 <sup>12</sup>	No Fill Fluid	_ _ _ 0 _ _	5	5
			Silicone Oil 200	_ _ _ 1 _ _	•	•
			Fluorinated Oil CTFE	_ _ _ 2 _ _	•	•
			Silicone Oil 704	_ _ _ 3 _ _	•	•
			Neobee® M20 <sup>11</sup>	_ _ _ 4 _ _	•	•
	f. Connection of Remote Seal to Meter Body**	No Capillary, No Nipple (Specify for VAM Unit Only)		_ _ _ 0 _ _	5	5
		Capillary Length	5 feet 1.5 m	_ _ _ A _ _	•	•
			10 feet 3.0 m	_ _ _ B _ _	•	•
			15 feet 4.5 m	_ _ _ C _ _	•	•
			20 feet 6.1 m	_ _ _ D _ _	•	•
			25 feet 7.5 m	_ _ _ E _ _	•	•
35 feet 10.7 m			_ _ _ F _ _	•	•	
5 feet 1.5 m			_ _ _ G _ _	•	•	
10 feet 3.0 m			_ _ _ H _ _	•	•	
15 feet 4.5 m			_ _ _ J _ _	•	•	
20 feet 6.1 m			_ _ _ K _ _	•	•	
25 feet 7.5 m		_ _ _ L _ _	•	•		
35 feet 10.7 m	_ _ _ M _ _	•	•			
	2 inch long SS nipple close-coupled	_ _ _ 2 _ _	6	6		
g. Seal Option**	None	_ _ _ _ 0 _	•	•		
	Std Gold Plated Seal Diaph. = 50 µin	_ _ _ _ 1 _	7	7		
	Teflon Coated Seal Diaphragm - only for anti-sticking	_ _ _ _ 4 _	7	7		

<sup>11</sup> Refer to 34-ST-00-128 for additional options, consult factory  
<sup>12</sup> Limited vacuum availability.  
<sup>12</sup> Minimum static pressure requirement. No vacuum allowed. See Specifications 34-ST-03-88 Figure 15



In-Line Gauge



Dual Head DP



All welded

STR74G  
STR73D

**Note:** When selecting required seal, you must specify only the 9 selections within the required seal type.

TABLE II		Description			Selection					
		No Seal Attached to Core Transmitter (Specify for VAM Unit Only)			0 0 0 0 0 0 0 0	21	21			
Seals	 Flush Flanged Seal**	Seal Type	Diaphragm Diameter	Flange Size	Flange Pressure Rating <sup>1</sup>		Selection			
		3.5"	3"	ANSI Class 150		AFA _____		•	•	
				ANSI Class 300		AFC _____		•	•	
		80mm	DIN DN80-PN40		AFM _____		•	•		
			Wetted Material	Diaphragm		Upper Insert		Selection		
		316L SS		316L SS		___ AA ___		•	•	
		Hastelloy® C-276		316L SS		___ AB ___		•	•	
		Hastelloy® C-276		Hastelloy® C-276		___ AC ___		•	•	
		Monel 400®		Monel 400®		___ AE ___		8	8	
		Tantalum <sup>5</sup>		316L SS		___ AF ___		8	8	
		Non-Wetted Material (upper)		CS (Nickel Plated)		___ 1 ___		•	•	
				316L SS		___ 2 ___		•	•	
Seal-Capillary Connection		Center Seal		___ 1 ___		•	•			
		Side Seal		___ 2 ___		9	9			
Calibration Rings		None		___ A ___		•	•			
		316L SS		___ B ___		10	10			
		Hastelloy® C-276		___ C ___		10	10			
		Monel 400®		___ D ___		10	10			
Flushing Connections and Plugs <sup>4</sup> (Metal plug material will be the same as Cal. ring material if metal plug is chosen )		None		___ 0 ___		•	•			
		One 1/4" with plastic plug		___ H ___		11	11			
		One 1/4" with metal plug		___ J ___		11	11			
		Two 1/4" with plastic plugs		___ M ___		11	11			
		Two 1/4" with metal plugs		___ N ___		11	11			
		One 1/2" with plastic plug		___ P ___		11	11			
		One 1/2" with metal plug		___ Q ___		11	11			
		Two 1/2" with plastic plugs		___ R ___		11	11			
		Two 1/2" with metal plugs		___ S ___		11	11			

Table II continued next page

<sup>\*\*</sup> Refer to 34-ST-00-128 for additional options, consult factory

<sup>1</sup> Standard facing 125-250 AARH RF (raised face) serrated surface finish.

<sup>4</sup> Plastic Plugs are TEMPORARY ONLY to protect threads and MUST be REMOVED before installation

<sup>5</sup> Tantalum Upper insert has Tantalum wetted parts and 316 SS or CS non-wetted parts

Note: Remote seal system pressure rating is body rating or seal rating, whichever is less.

STR74G  
STR73D

TABLE II		Description				Selection			
Seal Type	Diaphragm Diameter	Flange Size	Flange Pressure Rating <sup>1</sup>	Const. - See Spec. Figure 34-ST-03-104	Construction - See Spec. Figure 34-ST-03-104				
Seals (continued)		2.4"	1"	ANSI 150 ANSI 300	22	BCA _____ BCC _____	•	•	
			1-1/2"	ANSI 150 ANSI 300	22	BGA _____ BGC _____	•	•	
		2.9"	1-1/2"	ANSI 150 ANSI 300	22	CGA _____ CGC _____	•	•	
			2"	ANSI 150 ANSI 150	22	CDA _____ DAA _____	•	•	
		4.1"	1"	ANSI 150 ANSI 300	23	DCA _____ DCC _____	•	•	
			1-1/2"	ANSI 150 ANSI 300	23	DGA _____ DGC _____	•	•	
			2"	ANSI 150 ANSI 300	23	DDA _____ DDC _____	•	•	
			3"	ANSI 150 ANSI 300	22	DFA _____ DFC _____	•	•	
								•	•
		Wetted Material	<b>Diaphragm</b>		<b>Lower</b>		<b>Selection</b>		
			316L SS Hastelloy® C-276 Hastelloy® C-276 Monel 400® Tantalum Tantalum	316L SS 316L SS Hastelloy® C-276 Monel 400® 316L SS Hastelloy® C-276 Tantalum Clad	____ BA _____ ____ BB _____ ____ BC _____ ____ BE _____ ____ BF _____ ____ BG _____ ____ BH _____	• • • 8 8 8 13	• • • 8 8 8 13		
		Non-Wetted Material (upper, upper insert)	<b>Upper</b>		<b>Upper Insert</b>		<b>Selection</b>		
			316L SS Carbon Steel	316L SS 316L SS	____ 4 ____ ____ 5 ____	• •	• •		
		Bolts <sup>6</sup>	No Selection				____ 0 ____	•	•
		Flushing	None				____ 0 ____	•	•
		Connections and Plugs <sup>4</sup> (Metal plug material will be the same as Lower material, if metal plug is chosen - (SS Plug for CS Lower and Tantalum Clad)	One 1/4" with plastic plug One 1/4" with metal plug Two 1/4" with plastic plugs Two 1/4" with metal plugs One 1/2" with plastic plug One 1/2" with metal plug Two 1/2" with plastic plugs Two 1/2" with metal plugs				____ H ____ ____ J ____ ____ M ____ ____ N ____ ____ P ____ ____ Q ____ ____ R ____ ____ S ____	• • • • • • • •	• • • • • • • •
		Gasket	Viton Graphite Teflon®				____ V ____ ____ G ____ ____ T ____	• • •	• • •

Table II continued next page

\*\* Refer to 34-ST-00-128 for additional options, consult factory

<sup>1</sup> Standard facing 125-250 AARH RF (raised face) serrated surface finish.

<sup>6</sup> Bolt material will be same as Upper Material. However, if Table I bolts/nuts material is NACE or B7M, seal bolt material will be 304 SS NACE.

<sup>4</sup> Plastic Plugs are TEMPORARY ONLY to protect threads and MUST be REMOVED before installation

Note: Remote seal system pressure rating is body rating or seal rating, whichever is less.

TABLE II		Description					
Seal Type	Diaphragm Diameter	Flange Size	Flange Pressure Rating <sup>1</sup>		Selection		
 <p>Flange Seal with Extended Diaphragm**</p>	2.8"	3" (2.8" OD extension)	ANSI Class 150		EFA _____	•	
			ANSI Class 300		EFC _____	•	
	DIN DN80-PN40		EFM _____	•			
	3.5"	(3.70" OD extension)	ANSI Class 150		FGA _____	•	
			ANSI Class 300		FGC _____	•	
	DIN DN100-PN40		FGP _____	•			
	Wetted Material			Diaphragm	Ext. Tube	Selection	
				316L SS	316L SS	___EA___	•
				Hastelloy® C-276	316L SS	___EB___	•
	Hastelloy® C-276		Hastelloy® C-276	___EC___	•		
Non-Wetted Material (flange)		CS (Nickel Plated)		___7___	•		
Bolts		316L SS		___8___	•		
Extension Length		No Selection		___0___	•		
		2"		___2___	•		
		4"		___4___	•		
		6"		___6___	•		
No Selection	No Selection	No Selection		___0___	•		

Table II continued below

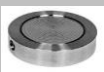

TABLE II		Description					
Seal Type	Diaphragm Diameter	Flange Size	Flange Pressure Rating Dependent on Customer Flange <sup>1</sup>		Selection		
 <p>Pancake Seal</p>	3.5"	3"	ANSI Class 150/300/600		GFA _____	•	
					Diaphragm	Body	Selection
	Wetted Material		316L SS		___GA___	•	
			Hastelloy® C-276		___GB___	•	
			Hastelloy® C-276		___GC___	•	
			Monel 400®		___GE___	8	
	Tantalum <sup>7</sup>		___GG___	8			
	Non-Wetted Material		No Selection		___0___	•	
	Bolts		No Selection		___0___	•	
	Calibration Rings		None		___A___	•	
		316L SS		___B___	10		
		Hastelloy® C-276		___C___	10		
		Monel 400®		___D___	10		
		Flushing		None		___0___	•
Connections and Plugs <sup>4</sup>		One 1/4" with plastic plug		___H___	11		
(Metal plug material will be the same as Cal. Ring material, if metal plug is chosen )		One 1/4" with metal plug		___J___	11		
		Two 1/4" with plastic plugs		___M___	11		
		Two 1/4" with metal plugs		___N___	11		
		One 1/2" with plastic plug		___P___	11		
		One 1/2" with metal plug		___Q___	11		
		Two 1/2" with plastic plugs		___R___	11		
Two 1/2" with metal plugs		___S___	11				

Table II continued below

<sup>2</sup> Refer to 34-ST-00-128 for additional options, consult factory

<sup>1</sup> Standard facing 125-250 AARR RF (raised face) serrated surface finish.

<sup>4</sup> Plastic Plugs are TEMPORARY ONLY to protect threads and MUST be REMOVED before installation

<sup>7</sup> Tantalum Body has Tantalum wetted parts and 316 SS non-wetted parts

Note: Remote seal system pressure rating is body rating or seal rating, whichever is less.

TABLE II		Description					
Seal Type	Diaphragm Diameter	Flange Size	Flange Pressure Rating <sup>1</sup>		Selection		
 <p>Chemical Tee "Taylor" Wedge</p>	3.5"	Taylor Wedge 5" O.D.	750 psi		HMO _____	16	
					Diaphragm	Body	Selection
	Wetted Material		316L SS		___HA___	•	
			Hastelloy® C-276		___HB___	•	
			Hastelloy® C-276		___HC___	•	
	Non-Wetted Material		No Selection		___0___	•	
Bolts		No Selection		___0___	•		
Styles		No Selection		___0___	•		
No Selection		No Selection		___0___	•		

Table II continued next page



TABLE II		Description						
Seal Type	Diaphragm Diameter	Threaded Process Connection Size (NPT Female)	Pressure Rating		Selection	STR74G	STR73D	
			CS Bolts	304 SS Bolts				
Seals (continued)   Seal with Threaded Process Connection	2.4"	1/2 NPT	2,500 psi	1,250 psi	JJG _____	•	•	
		3/4 NPT			KJG _____	•	•	
	1 NPT	JJG _____			•	•		
	4.1"	1/2 NPT	1,500 psi	750 psi	LJG _____	•	•	
		3/4 NPT			LKG _____	•	•	
	1 NPT	LLG _____			•	•		
	Wetted Material   Wetted Material			Diaphragm	Lower	Selection		
				316L SS	Carbon Steel	___JA___	•	•
				316L SS	316L SS	___JB___	•	•
				Hastelloy® C-276	316L SS	___JC___	•	•
		Hastelloy® C-276	Hastelloy® C-276	___JD___	•	•		
		Monel 400®	Monel 400®	___JE___	8	8		
		Tantalum	316L SS	___JF___	8	8		
		Tantalum	Hastelloy® C-276	___JG___	8	8		
Non-Wetted Material (upper)		CS (Nickel Plated)		___A___	•	•		
		316 Stainless Steel		___C___	17	17		
Bolts <sup>8</sup>		Carbon Steel		___C___	•	•		
		304 SS		___D___	•	•		
Flushing Connections and Plugs <sup>4</sup> (Metal plug material will be the same as Lower material, if metal plug is chosen - (SS Plug for CS Lower and Tantalum Clad)		None		___0___	•	•		
		One 1/4" with plastic plug		___H___	•	•		
		One 1/4" with metal plug		___J___	•	•		
		Two 1/4" with plastic plugs		___M___	•	•		
		Two 1/4" with metal plugs		___N___	•	•		
		One 1/2" with plastic plug		___P___	18	18		
		One 1/2" with metal plug		___Q___	18	18		
		Two 1/2" with plastic plugs		___R___	18	18		
		Two 1/2" with metal plugs		___S___	18	18		
Gasket		Viton		___V___	•	•		
		Graphite		___G___	•	•		
		Teflon®		___T___	•	•		

Table II continued below

<sup>1</sup> Standard facing 125-250 AARH RF (raised face) serrated surface finish.

<sup>4</sup> Plastic Plugs are TEMPORARY ONLY to protect threads and MUST be REMOVED before installation

<sup>8</sup> If Table I Bolts and Nuts material option is NACE, Bolts and Nuts will ship with Alloy Steel NACE and MAWP may change.

Note: Remote seal system pressure rating is body rating or seal rating, whichever is less.



TABLE II		Description					
Seal Type	Diaphragm Diameter	Flange Size	Pressure Rating		Selection	STR74G	STR73D
Seals (continued)   Sanitary Seal <sup>9</sup>	1.9"	2"	Customer clamp rating or 600 psi, whichever is less		MD0 _____	20	19
	2.4"	2-1/2"			NE0 _____	19	19
	2.9"	3"			PF0 _____	19	19
	4.1"	4"			QG0 _____	19	19
	Wetted Material		Diaphragm	Body	Selection		
			316L SS	316L SS	___NA___	•	•
	Non-Wetted Material		No Selection		___0___	•	•
	Bolts		No Selection		___0___	•	•
Styles		Tri-Clover Tri-Clamp®		___8___	•	•	
Gasket		No Selection		___0___	•	•	

Table II continued next page

TABLE II		Description					STR74G	STR73D	
Seal Type	Diaphragm Diameter	Size and Bolt Pattern	Seal Pressure Rating		Selection				
			C.S. Bolts	304 SS Bolts					
Seals (continued)		2.4" 8-Bolt Design	for 3" Pipe ≥ 4" pipe	2,500 psi	1,250 psi	RFK _____ RGK _____	•	•	
		2.4" 6-Bolt Design	for 3" Pipe ≥ 4" pipe	2,000 psi	1,000 psi	RPK _____ RQK _____	•	•	
		Wetted Material		Diaphragm	Lower Housing	Selection			
				316L SS	Carbon Steel	___ RA ___	•	•	
				316L SS	316L SS	___ RB ___	•	•	
				Hastelloy® C-276	316L SS	___ RC ___	•	•	
				Hastelloy® C-276	Hastelloy® C-276	___ RD ___	•	•	
		316L SS	N/A-Body Only <sup>10</sup>	___ SB ___	•	•			
		Hastelloy® C-276	N/A-Body Only <sup>10</sup>	___ SC ___	•	•			
		Non-Wetted Material		Body	Bolts <sup>10,11</sup>	Selection			
Carbon Steel 316L SS	Carbon Steel 316 SS			___ B ___ ___ C ___	8 •	8 •			
Bolts		No Selection		___ 0 ___	•	•			
Styles		No Selection		___ 0 ___	•	•			
Gasket		Viton		___ V ___	•	•			
		Graphite		___ G ___	•	•			
		Teflon®		___ T ___	•	•			

<sup>9</sup> All sanitary seals have dairy grade 3A approval.  
<sup>10</sup> Bolts are not included with "body only" selection.  
<sup>11</sup> If Table I Bolts and Nuts material option is NACE, seal bolt material will be 304 SS NACE.

Note: Remote seal system pressure rating is body rating or seal rating, whichever is less.

TABLE III	Agency Approvals (see data sheet for Approval Code Details)
Approvals	No Approvals Required
	FM Explosion proof, Intrinsically Safe, Non-incendive, & Dustproof
	CSA Explosion proof, Intrinsically Safe, Non-incendive, & Dustproof
	ATEX Explosion proof, Intrinsically Safe & Non-incendive
	IECEx Explosion proof, Intrinsically Safe & Non-incendive
	SAEx Explosion proof, Intrinsically Safe & Non-incendive
	INMETRO Explosion proof, Intrinsically Safe & Non-incendive
	NEPSI Explosion proof, Intrinsically Safe & Non-incendive
	KOSHA Explosion proof, Intrinsically Safe & Non-incendive
	EAC Customs Union (Russia, Belarus, Kazakhstan) Ex Approval, Flame proof, Intrinsically Safe
	CCoE Explosion proof, Intrinsically Safe & Non-incendive
	UATR Flameproof, Intrinsically Safe & Dustproof

STR74G	STR73D	
0	•	•
A	•	•
B	•	•
C	•	•
D	•	•
E	•	•
F	•	•
G	•	•
H	•	•
I	•	•
J	•	•
K	•	•

TABLE IV	TRANSMITTER ELECTRONIC SELECTIONS		
a. Electronic Housing Material & Connection Type	Material	Connection	Lightning Protection
	Polyester Powder Coated Aluminum	1/2 NPT	None
	Polyester Powder Coated Aluminum	M20	None
	Polyester Powder Coated Aluminum	1/2 NPT	Yes
	Polyester Powder Coated Aluminum	M20	Yes
	Dual Certified SS 316/316L (CF8M/CF)	1/2 NPT	None
	Dual Certified SS 316/316L (CF8M/CF)	M20	None
	Dual Certified SS 316/316L (CF8M/CF)	1/2 NPT	Yes
Dual Certified SS 316/316L (CF8M/CF)	M20	Yes	
b. Output/ Protocol	Analog Output		Digital Protocol
	4-20mA dc		HART Protocol
	4-20mA dc		DE Protocol
c. Customer Interface Selections	Indicator	Ext Zero, Span & Config Buttons	Languages
	None	None	None
	None	Yes (Zero/Span Only)	None
	Advanced	None	EN, GE, FR, IT, SP, RU, TU
	Advanced	Yes	EN, GE, FR, IT, SP, RU, TU
	Advanced	None	EN, CH, JP
	Advanced	Yes	EN, CH, JP
Standard (w/internal Zero, Span & Conf Buttons)	None	EN, RU	
Standard (w/internal Zero, Span & Conf Buttons)	Yes	EN, RU	

A __	•	•
B __	•	•
C __	•	•
D __	•	•
E __	•	•
F __	•	•
G __	•	•
H __	•	•
__ 0	•	•
__ A	•	•
__ D	*	*
__ E	*	*
__ H	*	*
__ J	*	*
__ S	u	u
__ T	u	u

TABLE V		CONFIGURATION SELECTIONS		
a. Application Software	Diagnostics			
	Standard Diagnostics			
b. Output Limit, Failsafe & Write Protect Settings	Write Protect	Fail Mode	High & Low Output Limits <sup>3</sup>	
	Disabled	High> 21.0mAdc	Honeywell Std (3.8 - 20.8 mAdc)	
	Disabled	Low< 3.6mAdc	Honeywell Std (3.8 - 20.8 mAdc)	
	Enabled	High> 21.0mAdc	Honeywell Std (3.8 - 20.8 mAdc)	
c. General Configuration	Factory Standard			
	Custom Configuration (Unit Data Required from customer)			

1	.	.
_ 1 _	.	.
_ 2 _	.	.
_ 3 _	.	.
_ 4 _	.	.
_ _ S	.	.
_ _ C	.	.

TABLE VI		CALIBRATION & ACCURACY SELECTIONS		
Accuracy and Calibration	Accuracy	Calibrated Range	Calibration Qty	
	NA	None	None	
	Standard	Factory Std	Single Calibration	
	Standard	Custom (Unit Data Required)	Single Calibration	

0	21	21
A	23	23
B	23	23

<sup>3</sup> NAMUR Output Limits 3.8 - 20.5mAdc can be configured by the customer or select custom configuration Table Vc

TABLE VII		ACCESSORY SELECTIONS	
a. Mounting Bracket	Bracket Type	Material	
	None	None	
	Angle Bracket	Carbon Steel	
	Angle Bracket	304 SS	
	Angle Bracket	316 SS	
	Marine Approved Bracket	Carbon Steel	
	Marine Approved Bracket (In - Line)	Carbon Steel	
	Marine Approved Bracket	304 SS	
	Marine Approved Bracket (In - Line)	304 SS	
	Flat Bracket	Carbon Steel	
Flat Bracket	304 SS		
Flat Bracket	316 SS		
b. Customer Tag	Customer Tag Type		
	No customer tag		
	One Wired Stainless Steel Tag (Up to 4 lines 26 char/line) Two Wired Stainless Steel Tag (Up to 4 lines 26 char/line)		
c. Unassembled Conduit Plugs & Adapters	Unassembled Conduit Plugs & Adapters		
	No Conduit Plugs or Adapters Required		
	1/2 NPT Male to 3/4 NPT Female 316 SS Certified Conduit Adapter		
	1/2 NPT 316 SS Certified Conduit Plug		
	M20 316 SS Certified Conduit Plug		
	Minifast <sup>®</sup> 4 pin (1/2 NPT) Minifast <sup>®</sup> 4 pin (M20)		

STR74G  
STR73D

0	.	.
1	.	.
2	.	.
3	.	.
8	y	.
9	.	.
4	y	.
A	.	.
5	.	.
6	.	.
7	.	.

_ 0 _	.	.
_ 1 _	.	.
_ 2 _	.	.

_ _ A0	.	.
_ _ A2	n	n
_ _ A6	n	n
_ _ A7	m	m
_ _ A8	n	n
_ _ A9	m	m

TABLE VIII		OTHER Certifications & Options : (String in sequence comma delimited (XX, XX, XX,...))	
Certifications & Warranty	None - No other options		
	NACE MR0175; MR0103; ISO15156 (FC33338) Process wetted parts only		
	NACE MR0175; MR0103; ISO15156 (FC33339) wetted and non-wetted parts		
	Marine (DNV,ABS,BV,KR,LR)		
	EN10204 Type 3.1 Material Traceability (FC33341)		
	Certificate of Conformance (F3391)		
	Calibration Test Report & Certificate of Conformance (F3399)		
	Certificate of Origin (F0195)		
	FMEDA (SIL 2/3) Certification (FC33337)		
	Over-Pressure Leak Test Certificate (1.5X MAWP) (F3392)		
	Cert Clean for O2 or CL2 service per ASTM G93		
	Extended Warranty Additional 1 year		
	Extended Warranty Additional 2 years		
	Extended Warranty Additional 3 years		
	Extended Warranty Additional 4 years		

00	*	*
FG	.	.
F7	c	c
MT	d	d
FX	.	.
F3	.	.
F1	.	.
F5	.	.
FE	j	j
TP	.	.
OX	e	e
01	.	.
02	.	.
03	.	.
04	.	.

TABLE IX		Manufacturing Specials	
Factory	Factory Identification		

0 0 0 0	.	.
---------	---	---

**MODEL RESTRICTIONS**

Restriction Letter	Available Only With		Not Available With	
	Table	Selection(s)	Table	Selection(s)
<b>b</b>	Select only one option from this group			
<b>d</b>			VIIa	1,2,3,5,6,7 ___
<b>c</b>	Id	___ 0, N, B ___		
<b>e</b>	Ib	_ 2 _ 2 _		
<b>j</b>	IVb	_ H _	Vb	_ 1,2,6 _
<b>m</b>	IVa	B, D, F, H _		
<b>n</b>	IVa	A, C, E, G _		
<b>u</b>	IVb	_ H _		
<b>y</b>			Ic	_ E _ _ _
<b>2</b>	Ie	___ 0 _		
		___ 2 _		
		___ 4 _		
<b>3</b>	If	___ 2 _	Ia	2 _ _ _ _
<b>4</b>	I	2 _ 0 _		
<b>5</b>	II	00000000	VIII	FG, F7, FX, OX, TP, MT, F1
<b>6</b>	Ic	_ B, D _ _	Ia	2 _ _ _ _
<b>7</b>			II	___ AF _ _
				___ BF _ _
				___ BG _ _
				___ BH _ _
				___ GG _ _
				___ JF _ _
<b>8</b>			VIII	FG, F7
<b>9</b>	II	___ AA2 _ _		
		___ AB2 _ _		
<b>10</b>			II	___ 0
<b>11</b>			II	___ A _
<b>13</b>	II	___ 0 _	II	___ T
<b>16</b>	I	2 _ _ _ _	VIII	FG, F7
<b>17</b>			II	___ JA _ _
<b>18</b>			II	___ JJG _ _
				___ JKG _ _
				___ JLG _ _
<b>19</b>			If	___ 2 _
<b>20</b>	If	___ A, G _		
<b>21</b>	I	___ 000		
<b>22</b>	Ic	_ E _ _ _		
<b>23</b>			II	00000000

FM Approvals<sup>SM</sup> is a service mark of FM Global  
 Hastelloy<sup>®</sup> is a registered trademark of Haynes International  
 Monel 400<sup>®</sup> is a registered trademark of Special Metals Corporation.  
 HART<sup>®</sup> is a registered trademark of HART Communication Foundation.  
 FOUNDATION<sup>TM</sup> Fieldbus is a registered trademark of Fieldbus Foundation.  
 Teflon<sup>®</sup> is a registered trademark of DuPont.  
 Neobee<sup>®</sup> is a registered trademark of Stepan Company.  
 Syltherm<sup>®</sup> 800 is a Trademark of Dow Corning Corporation  
 Klinger<sup>®</sup> C-4401 is a registered trademark of THERMOSEAL, INC  
 GRAFOIL<sup>®</sup> is a registered trademarks of GrafTech International Holdings Inc  
 Gylon<sup>®</sup> 3510 is registered trademark of Garlock Sealing Technologies  
 Tri-Clover Tri-Clamp<sup>®</sup> is a registered trademark of Alfa-Laval

**FIELD INSTALLABLE REPLACEMENT PARTS**

Description	Kit Number
Integrally Mounted Advanced Indicator Kit (compatible with all Electronic Modules)	50049846-501
Standard Display Module	50126003-501
Terminal Strip w/ Lightning Protection Kit for HART or DE Modules	50075472-532
Terminal Strip w/ Lightning Protection Kit for FFB/ <i>Profibus</i> Module	50075472-534
Terminal Strip w/o Lightning Protection for HART or DE Modules	50075472-531
Terminal Strip w/o Lightning Protection FFB Module	50075472-533
HART Electronics Module	50049849-501
HART Electronics Module w/ connection for external configuration buttons	50049849-502
DE Electronics Module	50049849-503
DE Electronics Module w/ connection for external configuration buttons	50049849-504
FFB Electronics Module Kit	50049849-509
FFB Electronics Module w/ connection for external configuration buttons	50049849-510
Note P - For part number pricing please refer to Web Channel.	

**PRODUCT MANUALS**

Description	Part Number
ST 700 SmartLine Transmitter User Manual - English	34-ST-25-44
ST 700 SmartLine Transmitter HART/DE Communications Manual - English	34-ST-25-47
ST 700 SmartLine Transmitter Safety Manual - English	34-ST-25-37
ST 700 SmartLine Transmitter Foundation Fieldbus Manual - English	34-ST-25-48
ST 700 SmartLine Transmitter Function Block Manual - English	34-ST-25-49

## Sales and Service

For application assistance, current specifications, ordering, pricing, and name of the nearest Authorized Distributor, contact one of the offices below.

### ASIA PACIFIC

Honeywell Process Solutions,  
Phone: + 800 12026455 or  
+44 (0) 1202645583

(TAC) [hfs-tac-support@honeywell.com](mailto:hfs-tac-support@honeywell.com)

#### Australia

Honeywell Limited  
Phone: +(61) 7-3846 1255  
FAX: +(61) 7-3840 6481  
Toll Free 1300-36-39-36  
Toll Free Fax:  
1300-36-04-70

#### China – PRC - Shanghai

Honeywell China Inc.  
Phone: (86-21) 5257-4568  
Fax: (86-21) 6237-2826

#### Singapore

Honeywell Pte Ltd.  
Phone: +(65) 6580 3278  
Fax: +(65) 6445-3033

#### South Korea

Honeywell Korea Co Ltd  
Phone: +(822) 799 6114  
Fax: +(822) 792 9015

### EMEA

Honeywell Process Solutions,  
Phone: + 800 12026455 or  
+44 (0) 1202645583

#### Email: (Sales)

[FP-Sales-Apps@Honeywell.com](mailto:FP-Sales-Apps@Honeywell.com)

or

(TAC)

[hfs-tac-support@honeywell.com](mailto:hfs-tac-support@honeywell.com)

#### Web

Knowledge Base search  
engine <http://bit.ly/2N5Vldi>

### AMERICAS

Honeywell Process Solutions,  
Phone: (TAC) (800) 423-9883  
or (215) 641-3610  
(Sales) 1-800-343-0228

#### Email: (Sales)

[FP-Sales-Apps@Honeywell.com](mailto:FP-Sales-Apps@Honeywell.com)

or

(TAC)

[hfs-tac-support@honeywell.com](mailto:hfs-tac-support@honeywell.com)

#### Web

Knowledge Base search  
engine <http://bit.ly/2N5Vldi>

*Specifications are subject to change without notice.*

---

#### For more information

To learn more about SmartLine Transmitters,  
visit [www.process.honeywell.com](http://www.process.honeywell.com)  
Or contact your Honeywell Account Manager

#### Process Solutions

Honeywell  
1250 W Sam Houston Pkwy S  
Houston, TX 77042

Honeywell Control Systems Ltd  
Honeywell House, Skimped Hill Lane  
Bracknell, England, RG12 1EB

Shanghai City Centre, 100 Jungi Road  
Shanghai, China 20061

[www.process.honeywell.com](http://www.process.honeywell.com)



34-ST-03-104  
February 2025

©~~2024~~-2025 Honeywell International Inc.